

KOLBE[®]

WINDOWS & DOORS

POCKETING MULTI-SLIDE DOOR SYSTEM

INSTALLATION INSTRUCTIONS

**READ AND COMPLETELY UNDERSTAND
THESE INSTRUCTIONS
BEFORE STARTING ANY INSTALLATION**

⚠ CAUTION

Lead-based paint may be present in older homes, and the removal of windows & doors may cause this paint to be disturbed. In order to minimize exposure to lead-based paint dust, please consult www.epa.gov/lead for more information.

NOTICE

Failure to install and maintain our product according to these instructions will void any warranty, written or implied. The installer is responsible for consulting the contractor, structural engineer, architect, or consumer, for proper installation according to local codes and/or ordinances.

⚠ CAUTION

Some codes require the use of pressure treated lumber to frame rough openings. Corrosion resistant materials, such as stainless steel or hot-dip galvanized steel, must be used for fasteners and anchors having direct contact with pressure treated lumber.

⚠ WARNING

Proper Eye and Hearing Protection must always be worn when installing, removing or performing adjustments to Kolbe window and door products.

NOTICE

Before applying sealant or adhesive pads, ensure the area to be sealed is clean, dry, and frost-free. Use color-matching or transparent sealant. Photos show contrasting sealant for clarity only. Use a dab of sealant behind any exterior-facing screws or nails.

NOTICE

It is highly recommended that Multi-Slide systems be installed in areas with sufficient overhangs to prevent water or air infiltration as required. The suggested overhang for the structure should match the height of the unit being installed. Failure to do so may result in structural damage to the surrounding area, finishes, and/or systems.

ITEMS REQUIRED BY INSTALLER

- | | | | |
|--------------------------------------|--|---|-----------------|
| • Hearing protection device | • Safety glasses/goggles | • Sealant (clear or color matching) | • Caulk gun |
| • Level | • Square | • Hammer | • Shims |
| • Phillips head screwdriver/bit | • Tape measure | • Flat head screwdriver | • Flashing tape |
| • Fiberglass insulation | • Putty knife | • Power drill with 7/64" (3mm) and 3/16" (5mm) bits | |
| • Sill Pan | • Closed cell foam backer rod in 1/2" (13mm) & 1" (25mm) diameters | | |
| • 7/16" deep well socket & extension | | | |

ITEMS PROVIDED BY KOLBE

- Unit Rough Opening & Elevation Drawings
- Frame - Head, Side Jambs, Sill and Post Interlock (to be assembled in field)
- Stationary Panel(s) (quantity will depend on unit configuration ordered)
- Active Panels (quantity will depend on unit configuration ordered)
- "Frame Assembly" screw package
- "Sill Install" screw package for wood sub-floor application (If masonry application, Tapcon screws supplied by other)
- "Head Jamb Install" screw package
- "Interlock" screw package
- "Post Interlock" screw package
- "Follower" screw package
- "Handle Stop" (installed on panel)
- Head Track Caps (quantity will depend on unit configuration ordered)
- Side Jamb Track Caps (quantity will depend on unit configuration ordered)
- Sill Track Caps (quantity will depend on unit configuration ordered) (qty 1 - for sill nosing/sill nosing extensions)
- Sill Nosing extensions (quantity depends on required performance standard)
- Nailing Fin (4 pieces - 1 for each side of frame)
- Foam corner seals for nail fin (one for each corner at the head of the unit)
- Frame Nosing corner seals (one for each frame nosing corner at the head of the unit)
- Handle set
- Strike - shipped loose or temporarily attached w/ slotted holes only (final screws drilled & installed after installation & wheel adjustment)
- Panel adjustment caps (qty depends on # of panels) (used on holes for roller adjustments & hole for securing stationary panel to frame)
- Foam Head Blocks (quantity depends on number of panels)
- Reticulated Foam for Sill weeps (quantity depends on length of sill)
- Astragal (Bi-parting units or 90° units only)
- Bi-parting astragal weep baffle
- Aluminum Panel Follower
- Wood Trim Board for Aluminum Panel Follower
- Post Interlock Dust Pad (for the bottom of the post interlock on the interior)(qty-1 for each post interlock)
- Tin shims (for sill only)
- 90° corner unit instruction sheet (supplemental sheet if needed)

UNIT PREPARATION

1. Before installing your Kolbe Multi-sliding Door System, unpack all components; check each against the packing slip and place back into packaging near the appropriate opening until ready to install. If there is any damage or missing parts, please let your distributor know immediately.
2. Often shop drawings are revised so system dimensions may change during the order and design phase. Before you begin, ensure you have the final approved shop drawings verified to be correct before the installer arrives.
3. Construct the opening according to the specifications outlined in the shop drawings.
4. Ensure that the finished pocket width and depth are accounted for. These dimensions are referenced in your drawings. (Note: Do not sheath until after the frame is installed), sheath according to the building codes in your area.

IMPORTANT
Do not sheath the pocket cavity until after the frame is installed.
Frame the interior pocket walls after the door system has been installed.

5. Build the interior walls after installation of the frame and panels. This will allow access for attaching the aluminum follower and wood trim to the back edge of the pocketing panel.
6. A certain amount of the interior pocket wall surfaces will be visible, so it is best to paint the interior surfaces black. Do this before the doors are permanently installed.

OPENING INSPECTION

1. Inspect the rough opening prior to installation for proper size requirements and ensure that it is plumb, square, and level.
2. The opening is to be 1" (26 mm) wider and 1/2" (13 mm) higher than the outside measurement of the door frame.
3. Size the masonry openings 1" (26 mm) wider and 1/2" (13 mm) higher than the nosing/exterior casing.

IMPORTANT The material/lumber quality and fasteners must be structurally adequate for design load requirements (the head carries the weight of the door - a minimum of 4-1/2" of wood framing material is required at the head - approximately 60 foot lbs/foot of board length.)

IMPORTANT Deflection resulting from fluctuating extra loads including live, wind, or snow, along the entire supported span must not exceed 1/8" (3mm), after calculating the presence of permanent loads and natural settling of the beam (material dependent) (Fig. 1)

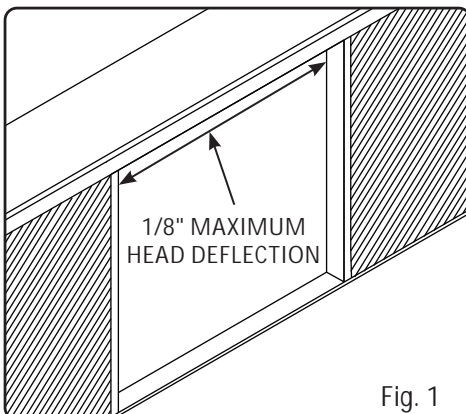

Verify that the concrete or sub-floor of the rough opening is level. The frame system may be shimmed to compensate for an uneven floor, but this may adjust the relationship of the system sill to the finished floor and may increase the overall height of the system in the opening. Any serious deflection in the concrete or sub-floor where the system is to be installed must be corrected prior to installation (Fig. 2).

⚠ WARNING
Sill sagging and/or humping will affect unit operation.

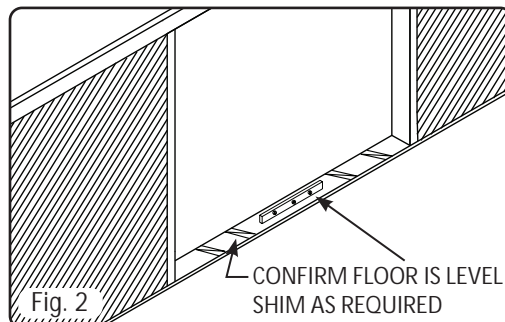

Ensure that all opening measurements match those noted on the drawings that are provided with the system (Fig. 3).

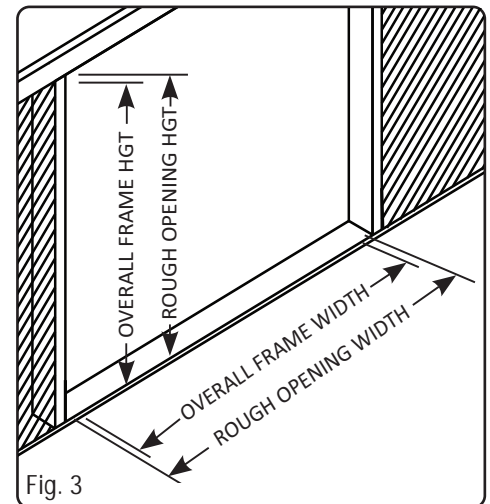

OPENING PREPARATION

Ensure the opening is clean and free of debris and/or installation materials. It is critical the sill is level for proper system operation. No crowns (humps) or valleys (dips) on the sub floor.

Pockets (special notes)

- Finish the exterior building according to your exposure level to the weather and local building codes.

Do not sheath the pocket cavity until the frame is installed.

- It is recommended to choose the color black for the pocket cavity.
- The post interlock seals the doors to the building and are supplied with the unit. They also require a continuous plane of building material for mounting, (Fig. 4).

IMPORTANT

Do not sheath the pocket cavity until after the frame is installed. Frame the interior pocket walls after the door system has been installed.

The Pocket Sizing Table below shows the finished pocket depth for 1-3/4" and 2-1/4" doors using 3/4" plywood.

Pocket Sizing Table					
Number of panels pocketing	Finished pocket depth		Number of panels pocketing	Finished pocket depth	
	1-3/4" Door	2-1/4" Door		1-3/4" Door	2-1/4" Door
1	4-5/8"	5-1/8"	6	16"	19"
2	6"	7"	7	18-1/2"	22"
3	8-1/2"	10"	8	21"	25"
4	11"	13"	9	23-1/2"	28"
5	13-1/2"	16"	10	26"	31"

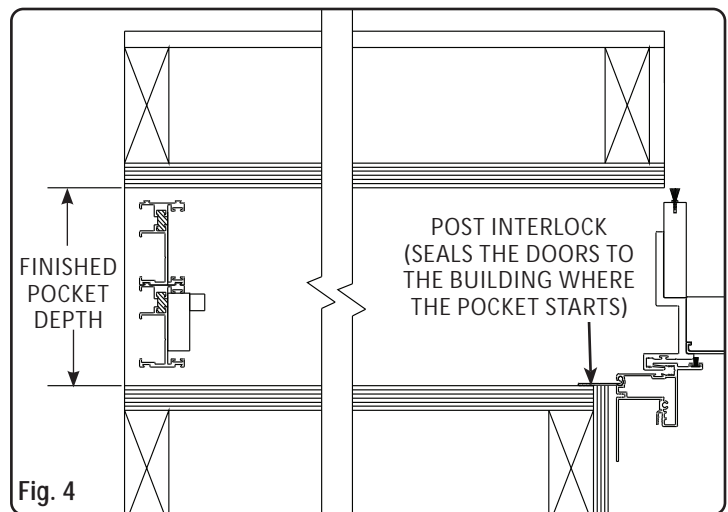

FLASHING REQUIREMENTS

Kolbe recommends following ASTM E 2112 installation guidelines for sealing and flashing exterior doors. Maintain a gap of at least 1/2" (12 mm) between the door frame and the rough opening structure, each jamb and height. Create a proper seal between the door and the building exterior. For more details, see our pamphlets *Sealant Information and Flashing Instructions*. These publications are available from your Kolbe window & door supplier or visit www.kolbewindows.com to download a copy.

SILL PAN FLASHING

A sill pan is **REQUIRED** for installation of a Multi-slide door system. Follow ASTM E 2112 installation standards when making and installing the sill pan.

- Make sill pan to rough opening dimensions and dry fit it in the opening. The interior leg is required to be a minimum of 3/4" high. The exterior leg (for pocketing units) will need to be the same height as the sill nosing with sill nosing extensions attached, so it may be a different height than the interior leg height, (Fig. 5).
- Install and attach sill pan to rough opening according to ASTM E 2112 standards, making sure that the sill pan is level once installed.

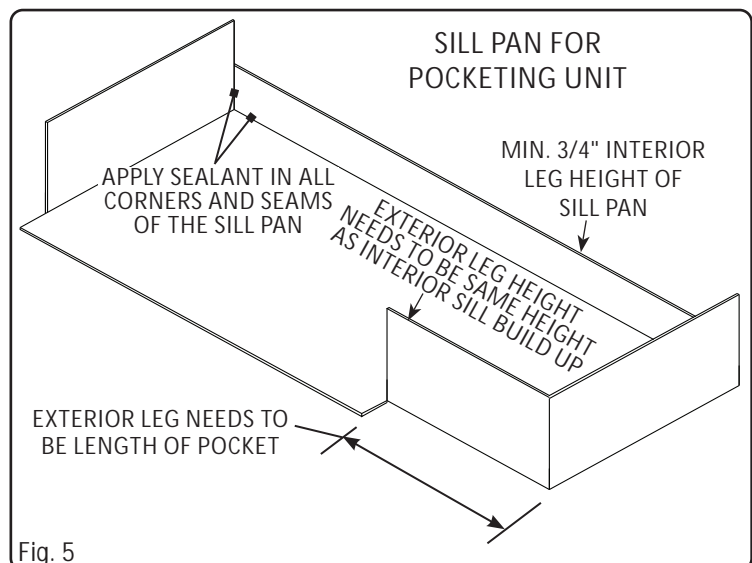

FRAME ASSEMBLY

NOTE: For 90° Corner Units, the head and sill frame corners at the 90° intersection will be attached upon installation into the opening.

- Ensure you have a clean flat surface to help protect the frame when assembling. Lay frame head, sill, side jamb(s) and post interlock(s) on the clean flat surface with the exterior side up.
- Slide nailing fin into each jamb nosing where needed, (Fig. 6).
- Apply the frame nosing corner seals to the top corner (45° angle) each side jamb/post interlock, (Fig. 7).
- Attach the side jamb(s) to the head using the screws supplied in the "Frame Assembly" screw package. Ensure the screws pass through the side jambs and into the screw bosses in the head, (Fig. 8). *(On the pocket side of a pocketing unit, the base side jamb is not supplied with the exterior nosing, this nosing called the post interlock will be applied in the steps that follow.)* (Fig. 9)
- Attach the side jamb frame nosing to the head jamb frame nosing using the screws provided in the "Frame Assembly" screw package.

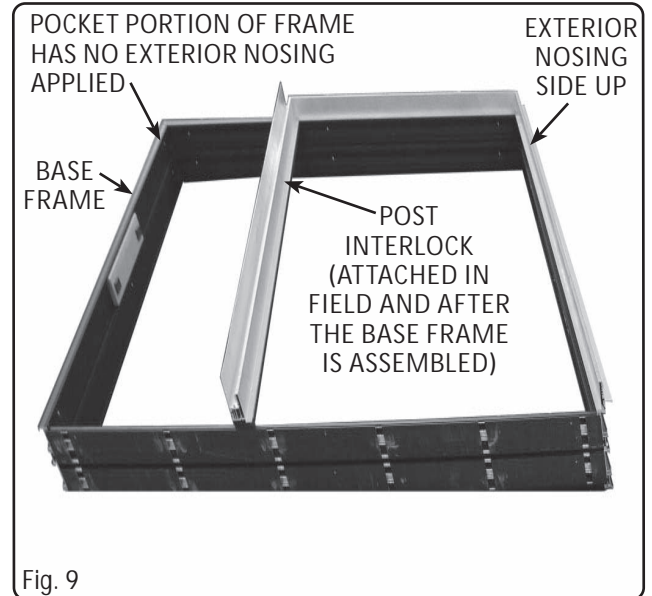
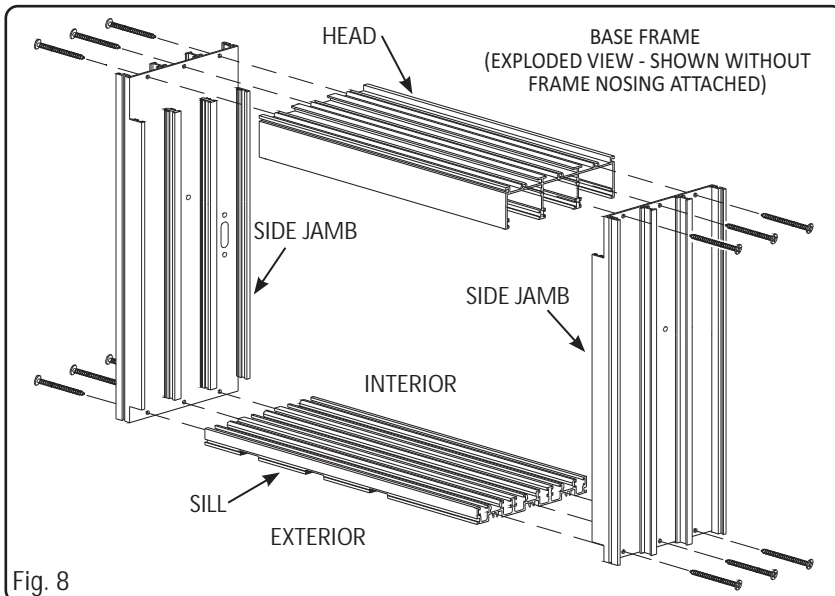
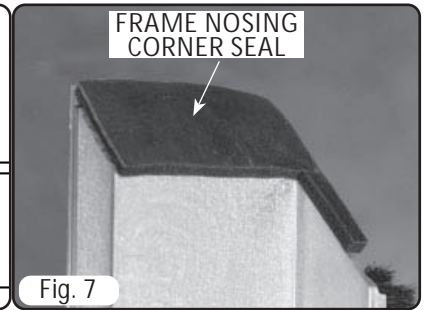
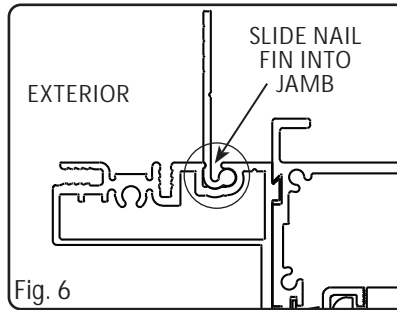

- Attach the side jamb(s) to the sill using the screws supplied in the "Frame Assembly" screw package. Ensure the screws pass through the side jambs and into the screw bosses in the sill nosing, (Fig. 8).
- Align the pre-drilled holes on the post interlock (Fig. 9) to the holes on the exterior of the pocket side of the frame (at the head, line up the post interlock flush with the frame nosing). Secure the post interlock to the frame head and sill using the provided screws in the "Post Interlock" screw package, (Fig. 10 & 11). **Do not over tighten screws. Over tightening the screws will cause the post interlock to collapse at the ends.**
- Secure the post interlock to the head nosing using the provided screw in the "Post Interlock" screw package, (Fig. 12).

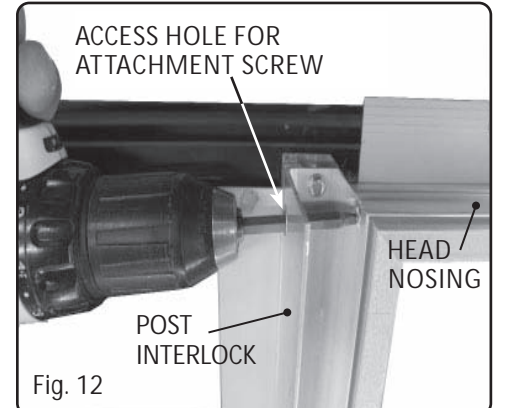
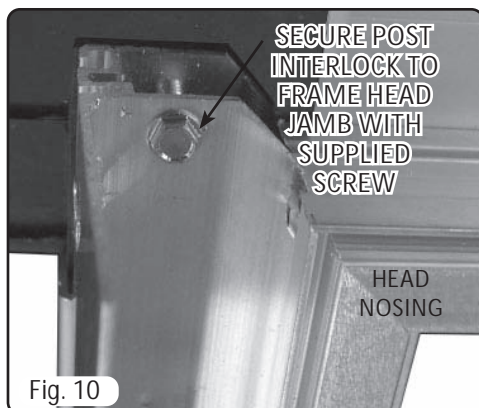

- On the interior, at the bottom of the post interlock, apply the post interlock dust pad as shown in (Fig. 13). Remove the backing and stick the pad in place.

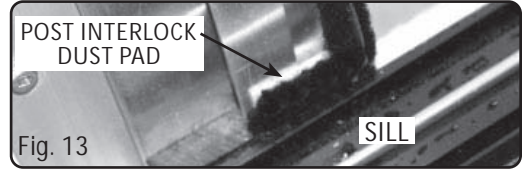

FRAME PREPARATION

- Fully fill the open cavities located at the head and sill of the side jambs with sealant (Fig. 14).
- On each end of the sill, fill the small gap between the sill nosing and the interior wood trim on the interior of the side jamb with sealant, (Fig. 15).

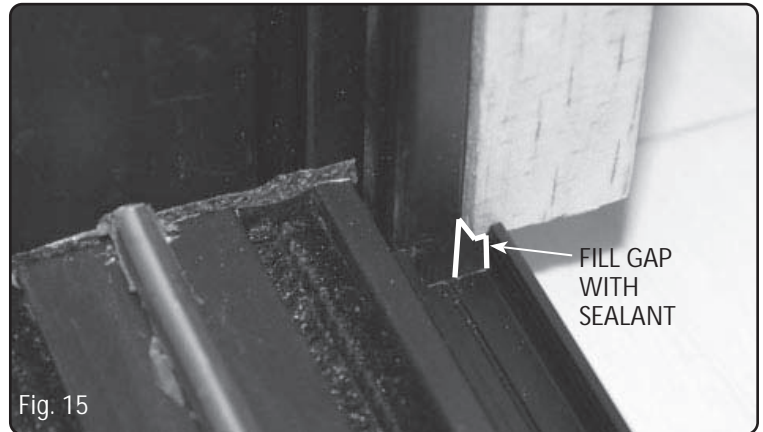
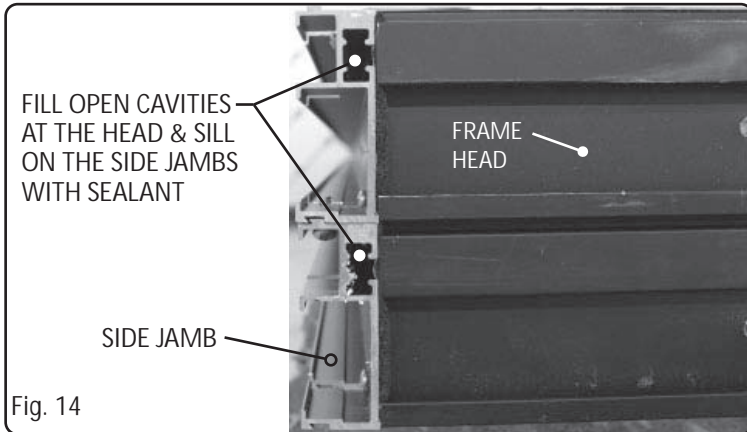

- Place a piece of reticulated foam into each weep slot on the sill nosing at the exterior, (Fig. 16).
- Apply the foam corner seal to the nailing fin on each corner at the head of the unit, (Fig.17).
- Run two 3/16" beads of sealant on the backside of the nail fin on the head and sides as shown in (Fig. 17).

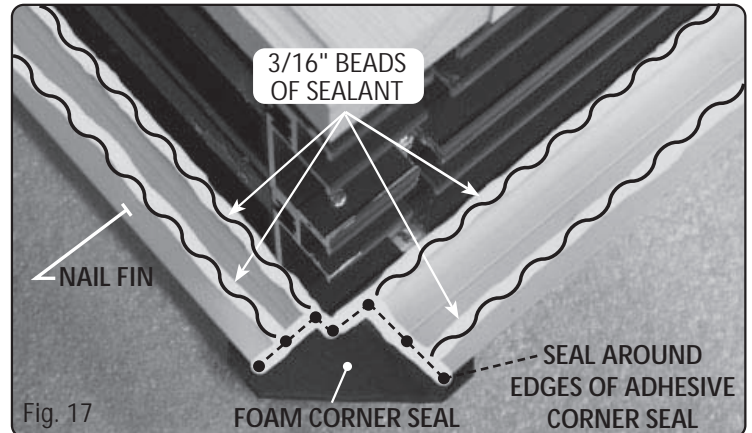
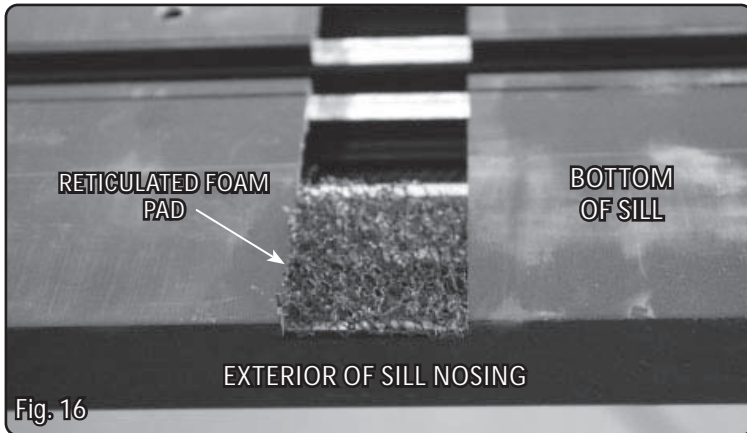

- On the bottom (underside) of the sill, apply a dab of sealant on each pre-drilled hole, (Fig. 18).
- Apply a 3/16" bead of sealant on the interior upturned leg of the sill pan where the back of the sill will contact the sill pan, (Fig. 19).

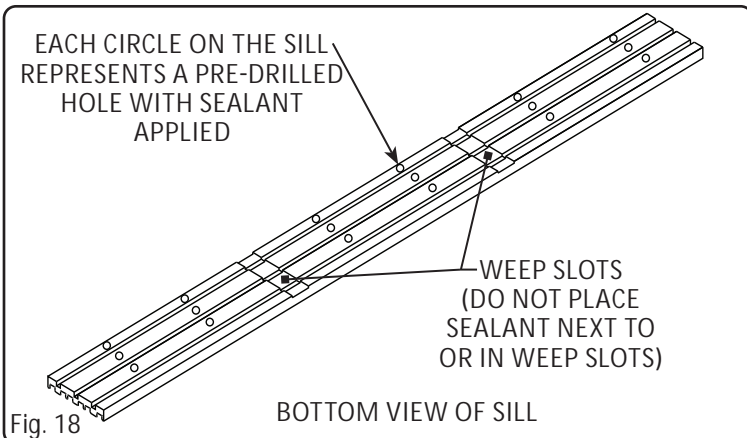

FRAME INSTALLATION

- Place assembled frame in rough opening. If it is a 90° unit the corner keys will need to be inserted into the head nosing and head track(s) at this time. See supplemental instruction for 90° corner units.
- Drill wood sub-floor through the factory pre-drilled holes located in the sill. Using a straight edge or level, verify that the sill is level and flat. Use the provided tin shims as needed to level the sill. Apply sealant in each pre-drilled hole in the sill. Attach using fasteners located in the "Sill Install" screw package. For 90° units ensure the sill pieces are properly aligned prior to fastening the sill to the sub-floor. There are no corner keys for the sill tracks. *(For masonry application, Tapcon screws are required and are supplied by others.)*
- Prior to attaching the head, square the frame to within the allowable tolerances. Use the supplied story board and a string line to verify the top track/head is level and flat. Start in the middle and work your way to each side, moving the story board next to each pre-drilled hole and then attaching the head to the opening through the pre-drilled holes using the screws located in the "Head Jamb Install" screw package. Note: Shims are needed for every screw hole location on the head jamb. Check to ensure distance between frame and string line is level after each screw has been placed.

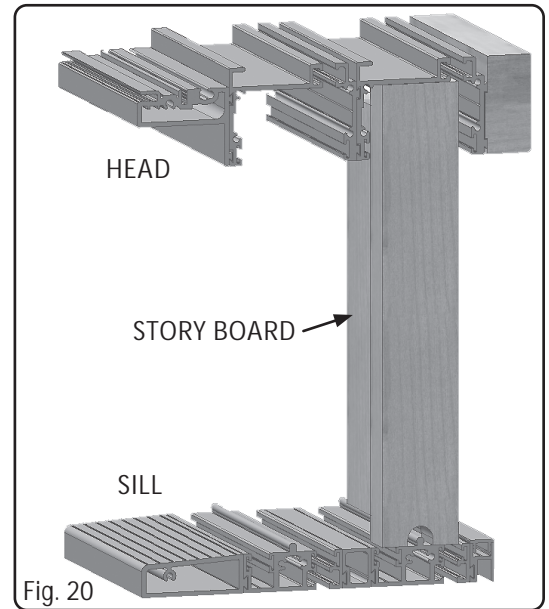

- Using a straight edge and/or level, verify that the side jambs are level and flat. Use shims as needed to level and straighten the jambs. Attach the side jambs through each of the factory pre-drilled holes using the screws located in the "Head Jamb install" screw package. Each door-opening cavity will have two screws with rubber bumpers in the accessory kit. Put one screw at the top and one at the bottom of each cavity.
- Cross measure the frame to confirm there is no variance larger than 1/8" per measurement and that the frame is square to within 1/8" horizontally and vertically, (Fig. 21).
- Ensure sill weep slots are not blocked or clogged. Remove debris as necessary.

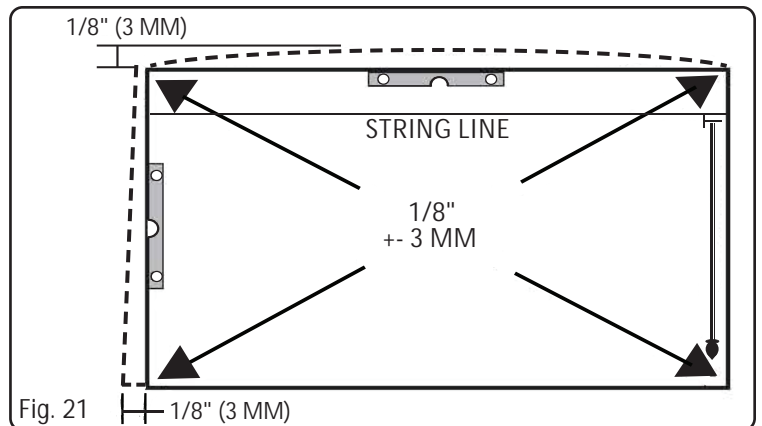

PANEL INSTALLATION (Panels are installed from the exterior of the unit)

- Beginning with panel marked #1, holding the panel at an angle toward the head track, insert the top of the panel into the inner most head track and swing the bottom of the panel inward until it is parallel with the top and sits with the wheels on the corresponding sill track. Repeat for all remaining panels in sequential order (Fig. 22).
- Mark and notch the bottom end of the aluminum follower to fit over the top of the sill nosing extensions prior to attaching the aluminum follower to the panel. The size of the notch is determined by the number of sill nosing extensions X 1/2" (Fig. 23).

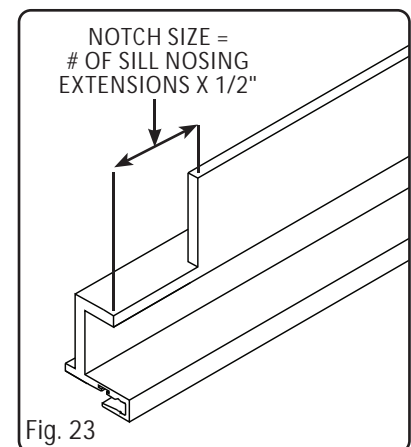
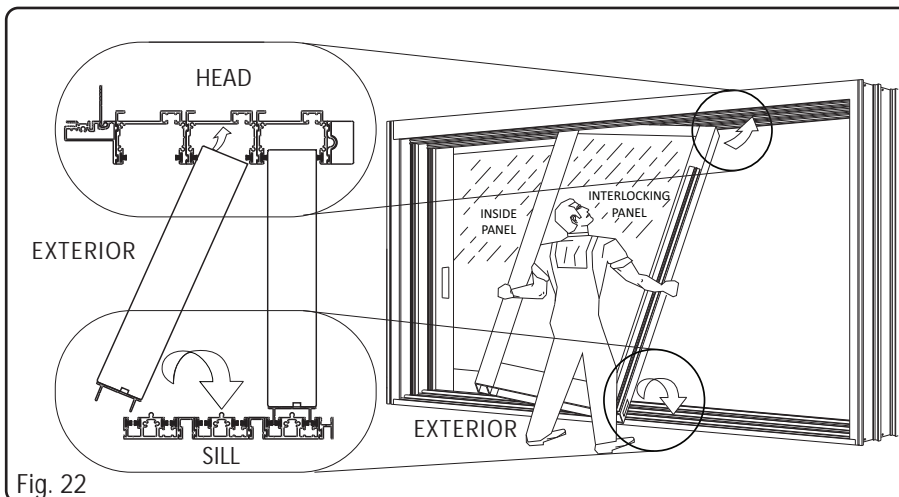

- Attach the aluminum follower to the back edge of the last panel (most exterior panel). Line up the holes/slots in the aluminum follower with the pre-drilled holes in the edge of the panel. Use the provided lag bolts and washers (found in the "follower" screw package) in the pre-drilled holes on the edge of the aluminum follower and panel to secure the aluminum follower in place. *(The washers need to be between the aluminum follower and the head of the bolt. Repeat for each pre-drilled hole (Fig. 24).*
- Attach the panel follower trim to the aluminum follower using the supplied screws in the "Interlock" screw package (Fig. 24).

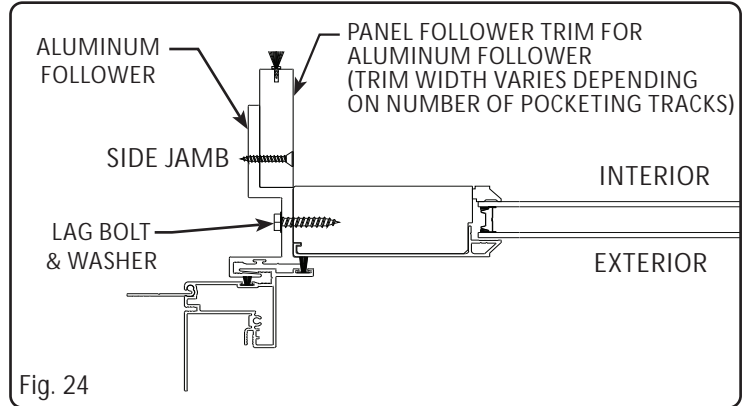

ASTRAGAL INSTALLATION

For Bi-parting doors

- Trim the interior astragal cover to fit over the sill nosing extensions. The amount that needs to be trimmed is determined by the number of sill nosing extensions X 1/2" (Fig. 25).
- Attach the astragal to the meeting panel without locking hardware installed.
- Line up the pre-drilled holes on the panel and astragal, then secure the astragal in place using the supplied screws from the "Astragal" screw package (Fig. 25).

For 90° units - See supplemental instruction for 90° corner units found on www.kolbewindows.com.

Fig. 26 Apply the bi-parting astragal weep baffle as shown in (Fig's 25 & 26).

- * Apply a bead of silicone sealant to the back of the baffle.
- * Position the baffle in the indicated location.
- * Press firmly to secure it in place.

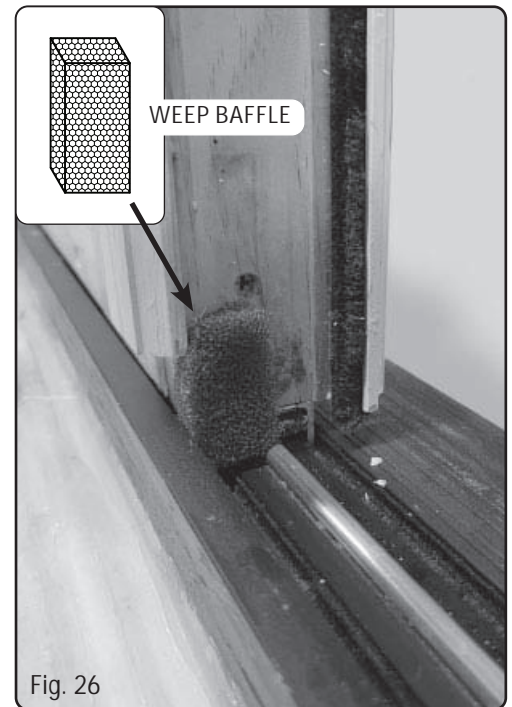
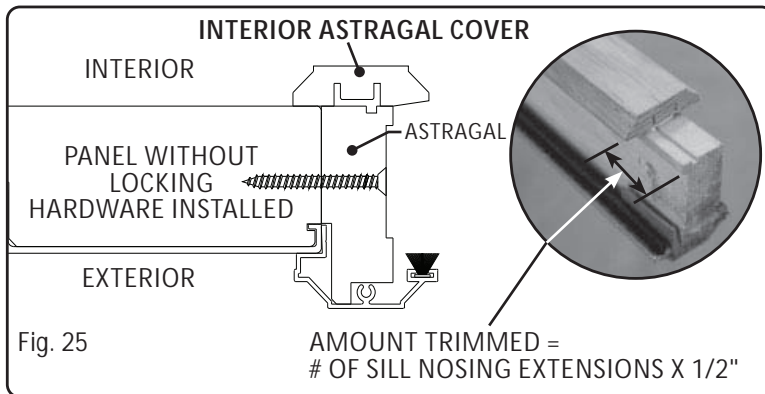

PANEL ADJUSTMENT

The panel rollers need to be adjusted for the unit to function properly. Slide the active panel open slightly, just enough to see the weatherstrip and side stop. Check for a consistent reveal/margin. To adjust the margin, remove the panel adjustment caps on the bottom panel rail. Insert a flat head screwdriver into the hole and turn. This will raise or lower one corner of the panel. When done with adjustments, plug the holes in the active panel with the panel adjustment caps, (Fig. 27). **DO NOT USE A POWER DRIVER!**

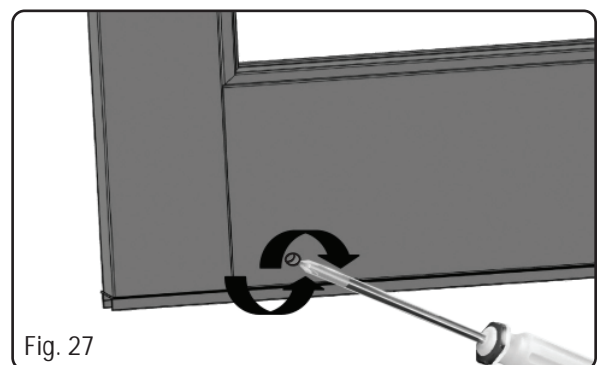

INTERIOR SILL NOSING EXTENSION APPLICATION

As required to meet performance standards, add the correct number of interior sill nosing extensions to the unit. Run sealant on the interior sill nosing and sill nosing extensions as shown in (Fig. 28). Ensure to completely seal the ends of the sill nosing extensions.

(Fig. 29) shows the sill nosing extensions and track cap filler correctly installed on the sill nosing.

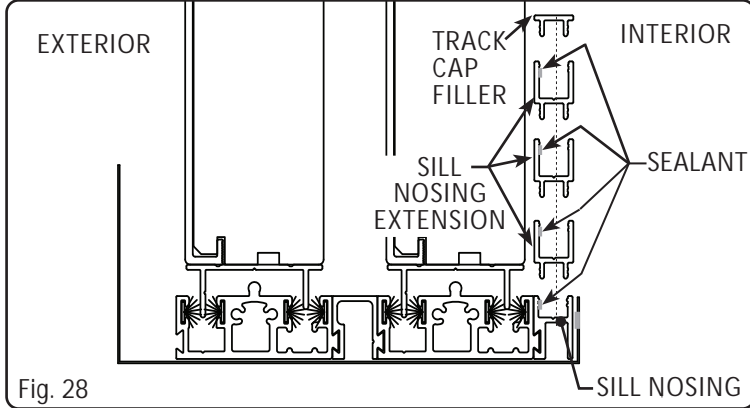

Fig. 28

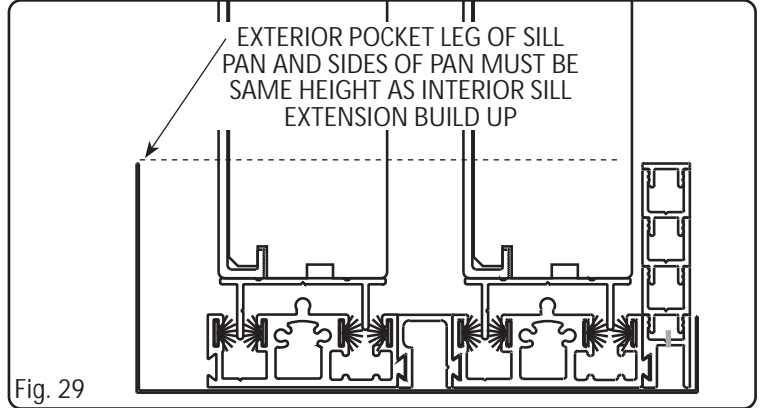

Fig. 29

FOAM BLOCK AIR BARRIER INSTALLATION

Please Note: The foam head block is shown in white for clarity purposes.

The foam head blocks installed on your unit will be black.

- Place each foam head block where the head track cap ends.
- Temporarily place the head track cap in the head track to determine the foam block's placement, (Fig. 30 & 31).
- Ensure the foam head block extends 1/16" to 1/8" beyond the end of the head track cap, (Fig. 31).
- After determining the proper position of the foam block, run sealant on the back, sides, and top of the block, (Fig. 31).

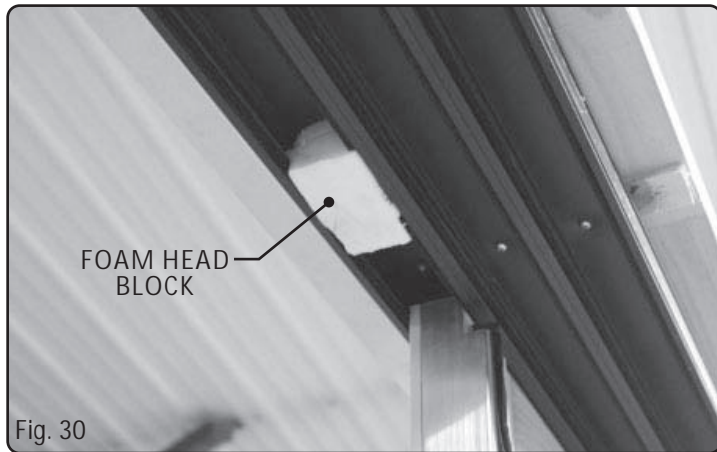

Fig. 30

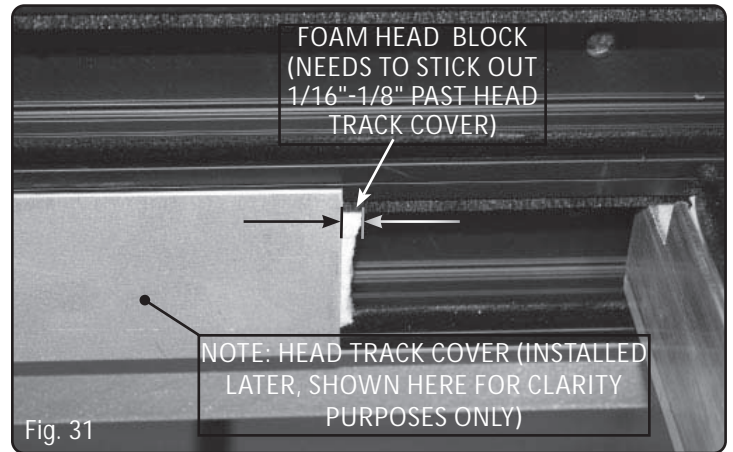

Fig. 31



Fig. 32

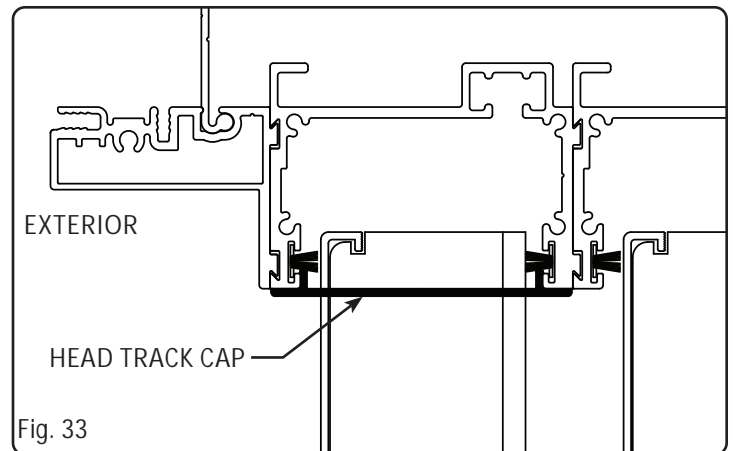

Fig. 33

TRACK CAP INSTALLATION

Install the head track caps on the exterior facing tracks: Before installation, identify the track for each cap by its overall length. Ensure the head track cap fits tightly against the side jamb and gently insert it into place, (Fig. 33, previous page).

Install the side jamb track caps on the exterior of the locking side jamb by fitting it to the head jamb and gently insert it in place, (Fig. 34).

Install the sill track caps on the exterior sill tracks: Determine what track each cap goes into based on its overall length. Ensure the track cap is tight against the side jamb and gently insert it in place, (Fig. 35).

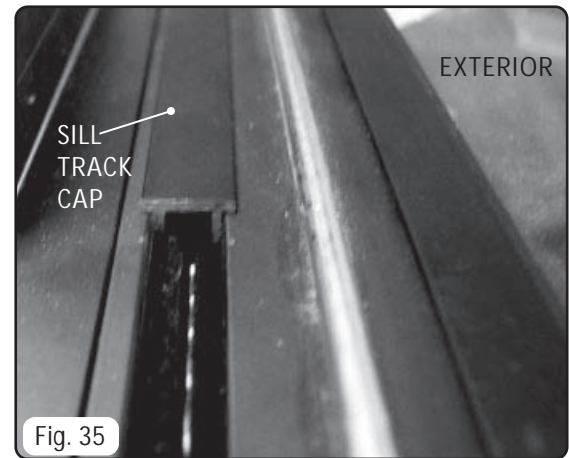
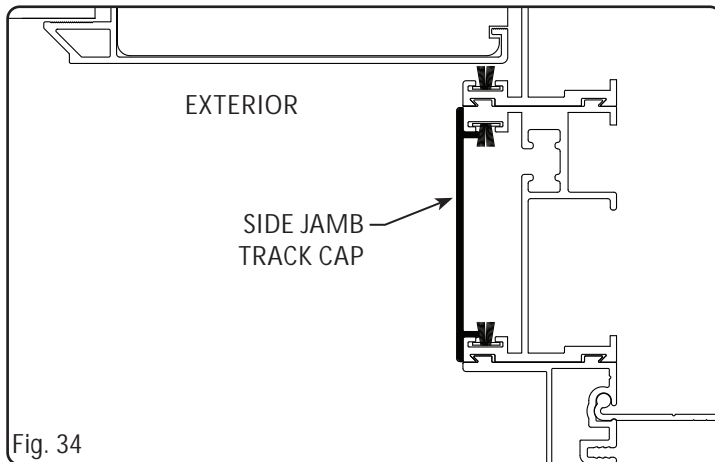

INTERIOR POCKET WALL

Complete the interior pocket wall according to the specifications outlined in the shop drawings.

INSULATION AND INTERIOR CASING/TRIM

Kolbe recommends installing fiberglass insulation in the gap between the door frame and the rough opening. *(Fill the space between the rough opening header and the frame head with standard fiberglass insulation or something that can be compressed. Do NOT use expanding foam, as it will not allow the head to be adjusted.)* Using a putty knife, loosely fill the entire depth of the gap with insulation. Apply interior casing/trim and secure with finishing nails.

⚠ CAUTION

Over-packed insulation can lessen the insulation effectiveness and distort the frame, resulting in poor panel operation. If you are using a foam type insulation, it must be a low expansion type foam made for window and door installation and used in conjunction with fiberglass insulation. Follow the manufacturer's instructions for proper application of the foam.

HARDWARE

Please refer to the "CARE AND MAINTENANCE OF WINDOW AND DOOR HARDWARE" manual for comprehensive instructions on maintaining your door hardware. Manual can be found on the Kolbe website.

RECYCLING

- Care must be taken to properly recycle or dispose of old materials.
- Separate recyclable materials from non-recyclable materials.
- Please consult with local or state authorities regarding proper disposal of non-recyclable materials.

Contact your Kolbe window and door supplier or visit us at www.kolbewindows.com for further information.

THANK YOU
FOR PURCHASING KOLBE PRODUCTS

Kolbe & Kolbe Millwork Co., Inc. reserves the right to change specifications without notice.

2026 Kolbe & Kolbe Millwork Co., Inc.