



WINDOWS & DOORS

Ultra Series, Heritage Series &
Complementary VistaLuxe® WD LINE
SLIDING DOOR
2 & 3-Wide FRAME ASSEMBLY
INSTALLATION INSTRUCTIONS

**READ AND COMPLETELY UNDERSTAND
THESE INSTRUCTIONS
BEFORE STARTING ANY INSTALLATION**

⚠ CAUTION

Lead-based paint may be present in older homes, and the removal of windows & doors may cause this paint to be disturbed. In order to minimize exposure to lead-based paint dust, please consult www.epa.gov/lead for more information.

Contents

Introduction	Page 1
ITEMS REQUIRED.....	Page 2
ITEMS SUPPLIED BY KOLBE.....	Page 2 & 3
PRELIMINARY PREPARATION.....	Page 3
PREPARE ROUGH OPENING.....	Page 4
FRAME ASSEMBLY:	Page 4
1. <i>Attach Head Jamb to Side Jambs</i>	
2. <i>Attach Sill to Side Jambs; For 3-wide units</i>	
3. <i>For 2-wide & 3-wide units</i>	
STATIONARY PANEL PREPARATION (IF APPLICABLE):	Page 5 & 6
<i>Attach sill filler to stationary panel</i>	
SIDELITE PANEL PREPARATION (IF APPLICABLE):	Page 6
<i>Attach sill filler to sidelite panel</i>	
SIDELITE PANEL INSTALLATION (IF APPLICABLE):	Page 6 & 7
<i>Apply Sealant, Install sidelite panel in frame, Interior Stops</i>	
STATIONARY PANEL INSTALLATION (if applicable):	Page 7
<i>Place sealant on sill and side jamb</i>	
<i>Install stationary panel in frame</i>	
SELECT INSTALLATION TECHNIQUE:	Page 8
<i>Technique #1, Installation Clip, Technique #2, Screwing Through the Frame</i>	
SEALANT AND FLASHING:	Page 9
INSTALLATION TECHNIQUE 1: INSTALLATION CLIPS:	Page 10
INSTALLATION TECHNIQUE 2: INSTALL UNIT IN OPENING BY SCREWING THROUGH THE FRAME ...	Page 11 & 12
SECURE THE SILL:	Page 13
FRAME PREPARATION FOR ACTIVE PANEL:	Page 14
UNITS WITH 2-1/4" PANELS ONLY:	Page 14
ACTIVE PANEL INSTALLATION:	Page 14
ADJUSTMENTS:	Page 15
ADDITIONAL FASTENING:	Page 16
COMPLETE THE EXTERIOR:	Page 16
INSULATION & INTERIOR CASING/TRIM:	Page 16
INTERIOR FINISHING:	Page 16
REMOVAL OF PROTECTIVE FILMS:	Page 16
CLEANING:	Page 16
HARDWARE:	Page 17
INSULATING GLASS:	Page 18
RECYCLING:	Page 18

INTRODUCTION

These instructions cover the assembly of 2-, and 3-wide, 1 3/4" or 2 1/4" wide panels with either narrow or wide stiles and rails. The instructions apply to both standard and impact-rated units. The examples shown features active/fixed/sidelite operation with the left panel moving (as seen from the outside); for fixed/active/sidelite units, reverse the directions. Units are typically installed in wood or concrete/masonry walls, with the rough opening lined with a 1-1/2" (38mm) thick wood buck. For other wall conditions, contact your Kolbe window and door supplier. Additional information is available at www.kolbewindows.com. For clarity, the illustrations throughout these instructions feature extruded aluminum units.

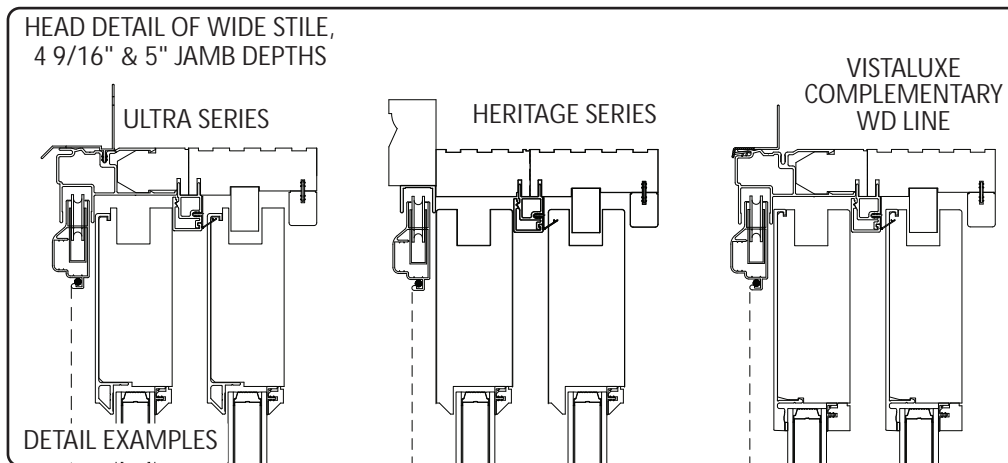
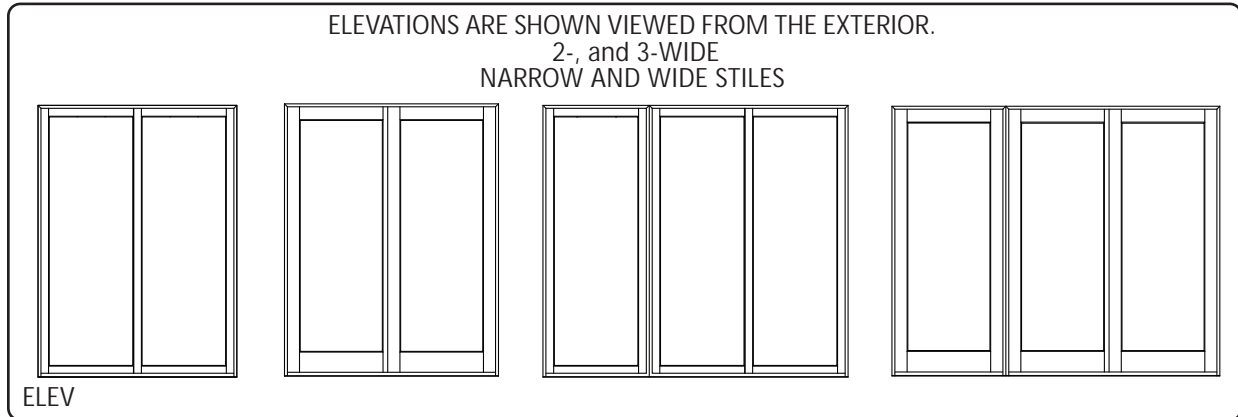

NOTICE

Proper installation and regular maintenance of Kolbe windows and doors are crucial for preserving the quality of our products. Failure to follow these instructions for installation and maintenance will void any warranty, whether written or implied. The installer is responsible for consulting with the contractor, structural engineer, architect, or consumer to ensure installation complies with local codes and ordinances.

NOTICE

Certain building codes require pressure-treated lumber to line rough openings. Fasteners and anchors in direct contact with pressure-treated lumber must be made from corrosion-resistant materials, such as stainless steel or hot-dip galvanized steel.

NOTICE

Before applying sealant, make sure the surface is clean, dry, and free of frost. Choose a color-matching or transparent sealant. The photos use contrasting sealant for clarity and demonstration purposes only.

⚠ WARNING

Improper use of hand or power tools may lead to personal injury or product damage. Always follow the manufacturer's instructions for safe equipment operation.

⚠ WARNING

Proper Eye and Hearing Protection must always be worn when installing, removing or performing adjustments to Kolbe window and door products.

NOTICE

Please read and fully understand these instructions before beginning the assembly or installation of Kolbe window and door products.

PRELIMINARY PREPARATION

1. **Unpacking:**
Remove and properly dispose of all shipping and packaging materials. These materials may include the protective shipping film and covers on the exterior of the frame, cardboard wrapping, skid plates, factory bracing, or factory applied ridged or strap handles attached to the frame.
2. **Positioning:**
Place the door on a clean, flat work surface with the exterior side facing up.
3. **Assessment:**
Ensure the unit is undamaged. Take note of its size dimensions for reference. Contact your Kolbe door supplier if you find damage or size discrepancies.
4. **Hardware Check:**
Verify that all necessary hardware, such as screws, brackets, handles, is present and accounted for.

ITEMS REQUIRED BY INSTALLER

- | | | |
|---|--|--|
| <ul style="list-style-type: none"> • Hearing protection device • Sealant • Level • Hammer • Phillips head screwdriver or bit • Standard screwdriver or bit • Fiberglass insulation • Power drill • 5/32" T-handle Allen Wrench • Closed cell foam backer rod in 1/2" (13mm) diameter and 1" (25mm) diameter • 4d finish nails for panel bumper • 3/32" (2mm), 7/64" (3mm), 9/64" (4mm) and 3/16" (5mm) drill bits | <ul style="list-style-type: none"> • Safety glasses/goggles • Caulk gun • Square • Shims • Tape measure • Flashing tape • Putty knife | <p><u>For temporary nailing through nailing fin:</u></p> <ul style="list-style-type: none"> • 1-1/2" (38mm) or longer galvanized roofing nails <p><u>For Installation Technique 1, Installation Clips:</u></p> <ul style="list-style-type: none"> • Kolbe installation clips • #8 x 3/4" (19mm) Phillips flat head screws • #8 x 1-3/4" (44mm) Phillips flat head screws or 8d common nails <p><u>For Installation Technique 2, Screw Thru Frame:</u></p> <ul style="list-style-type: none"> • #10 x 2-1/2" (64mm) Phillips flat head screws • #8 x 3" (76mm) flat head screws |
|---|--|--|

ITEMS SUPPLIED BY KOLBE FOR FRAME ASSEMBLY (For units with shipped loose frame and sash)

IMPORTANT: Units shipped frame assembled from the factory, will not have this screw pack included. Screws are packaged based off 3-wide door requirements. 2-wide doors will have extra screws when installation is complete.

- Sill
- Head Jamb - 45° angle on each end w/ corner keys installed
- Side Jamb - 45° angle at top end
- #8 x 2-1/4" Phillips Oval Head WS ZYel screws (Qty 12)
for attaching head jamb to side jambs



- #8 x 1-3/4" Phillips Flat Head SMS 18-8SS screw (Qty 16)
12- for attaching side jamb to sill assembly
4- for securing head & side brickmould(wood units only)



- #7 x 5/8" Phillips Flat Head SMS Self Sealing screws (Qty 4)
for attaching head nosing to side nosing (**Extruded units only**)



- #8 x 3/4" Phillips Pan Head SMS 18-8SS screws (Qty 4)
for attaching sill nosing to side jamb nosing



Screws are shown to scale

ITEMS SUPPLIED BY KOLBE FOR UNIT INSTALLATION

IMPORTANT: Screws are packaged to meet the requirements for 3-panel doors. For 2-panel doors, there will be extra screws left over after installation.

● Indicates a part that is temporarily installed on a unit in frame-assembled configurations.

Unit frame and panels (frame may be assembled or KD, stationary and sidelite panels may be installed or loose)

- #10 x 3" Phillips Flat Head screw (Qty 5)

For securing sidelite sill filler to sub-floor



- #8 x 3" Phillips Flat Head screw (Qty 9)

For securing interior still stop to sub-floor



- #10 x 1-3/4" Phillips Flat Head screw (Qty 6)

For securing sash retainer bracket to head jamb



- #8 x 2-1/2" Phillips Pan Head screw (Qty 2)

For side jamb keeper



- #8 x 2-1/4" Phillips Oval Head WS ZYel screws (Qty 6)

For attaching head jamb to side jambs



- #8 x 1-3/4" Phillips Flat Head SMS 18-8SS screw (Qty 8)

- 6 for attaching side jamb to sill assembly
- 2 for securing head & side brickmould (wood units only)



- #7 x 5/8" Phillips Flat Head SMS Self Sealing screws (Qty 2)

For attaching head nosing to side nosing (Extruded units only)



- Stationary Panel Sill Filler (Qty 1)

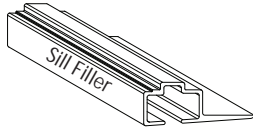

- Sidelite Panel Sill Filler (Qty 1)

- Panel Adjustment Caps (Qty 2)



- Square Glazing Bead - Profile 1076 (Qty 1/sidelite)



Footnotes: Screws are shown to scale

- Panel Bumper Length: 4-3/4"

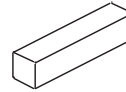

- Nailing Fin foam corner seal (Qty 2) (Used on Clad units)



- Head Jamb Interior Stop Width for 5-0 unit: 56-7/8" Width for 6-0 unit: 68-7/8" Width for 6-6 unit: 74-7/8" Width for 8-0 unit: 92-7/8"

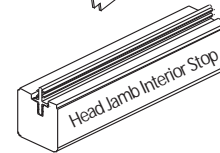

- 2pc Active Panel Head Parting Stop

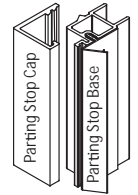

- Wood Sash Retainer Bracket* (for doors w/ 1-3/4" panels only) Width for 5-0 unit: 56-7/8" Width for 6-0 unit: 68-7/8" Width for 6-6 unit: 74-7/8" Width for 8-0 unit: 92-7/8"

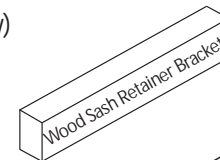

- Wood Stationary Panel Parting Stop



For doors with 2-1/4" panels

- Aluminum Head Track Guide* Width for 5-0 unit: 56-7/8" Width for 6-0 unit: 68-7/8" Width for 6-6 unit: 74-7/8" Width for 8-0 unit: 92-7/8"

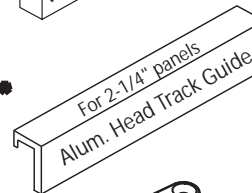

- Meeting Stile Frame Bracket (2)



- Sill Panel Retainer Bracket (1)



- Head Panel Retainer Bracket (1)

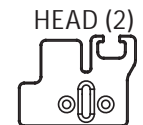

- #8 x 3/4" Phillips Pan Head SMS 18-8SS screws (Qty 12) for securing aluminum head track guide to head jamb



- #9x 3" Phillips Flat Head (Qty 6) for meeting stile frame bracket



- #9x 2" Phillips Flat Head (Qty 8) for panel retainer bracket



PREPARE ROUGH OPENING

Before installation, inspect window rough openings to ensure they meet proper size requirements per window. Ensure it is plumb, square, and level for a precise fit.

1. **IMPORTANT** The material/lumber quality and fasteners must be structurally adequate for design load requirements.
2. The rough opening must be lined with a 1-1/2" (38mm) thick wood buck.
3. Typically the rough opening is to be sized 1/2" (13mm) wider and 1/2" (13mm) higher than the outside measurement of the door frame. Size the masonry opening 1/2" (13mm) wider and 1/4" (6mm) higher than the clad nosing/interior casing (**verify sizing with local building code requirements**).
4. The rough opening must be plumb, square, level, and in plane. Remedy and discrepancies.
5. Ensure individual construction members are not twisted.
6. The sill plate beneath the unit must be perfectly level for proper unit operation.

CAUTION

When installing on a concrete floor, begin by installing a subfloor to ensure a level surface. Apply caulk rated for concrete adhesion to the subfloor and secure it to the concrete. For installations involving exterior rigid foam insulation panels on walls, place solid blocking material behind the brickmould or nailing fin to provide adequate support when fastening the unit into the opening.

FRAME ASSEMBLY

Attach Head Jamb to Side Jamb:

(Fig. 1) Mark the clearance hole locations on each end of the head jamb, measuring 1/2" (13mm) from the side edge towards the center of the unit. Space the holes evenly, starting 1-1/4" (19mm) up from the back edge of the wood portion.

Use a 3/16" (5mm) drill bit to pre-drill holes at each marked location on both ends. For wood units, also pre-drill a 3/16" hole on each end of the head jamb brickmould, placing the hole 1" (26mm) in from the end and centered on the brickmould.

Dry fit the head jamb and side jambs. Drill 3/32" (2mm) pilot holes through the clearance holes in the head jamb and down into each side jambs.

(Fig. 2) Apply a 3/16" (5mm) bead of sealant to the top of each side jamb assembly. Attach the head jamb to the side jambs by fastening through the clearance holes in the head jamb and into the side jamb, using three #8 x 2-1/4" (57mm) screws (supplied by Kolbe) on each end.

For extruded units only: Use one #7 x 5/8" (16mm) flat head screw (supplied) through the side nosing into the corner key on each side of the unit.

For wood units only: Secure the head brickmould to the side brickmould on both sides with a #8 x 2-1/4" (57mm) screw (supplied).

Attach Sill to Side Jamb: *For 3-Wide Units:*

- (Fig. 3) Connect and join the sills together before attaching the frames. Slide the main door sill end key and the sidelite sill end key together.

- (Fig. 4) Run an 1/8" (3mm) bead of sealant into the sill trim nosing groove in the front edge of the sill. Snap the back of the sill trim nosing into the groove, and push it back tightly into the groove, then rotate sill trim nosing down.

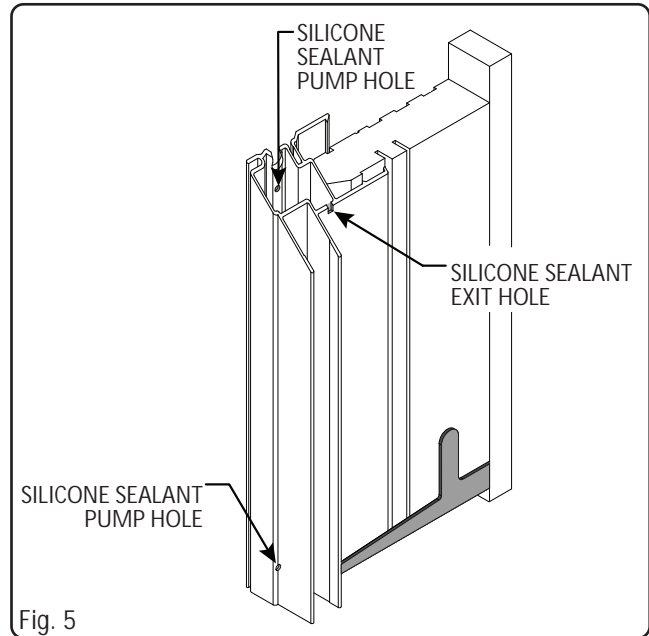
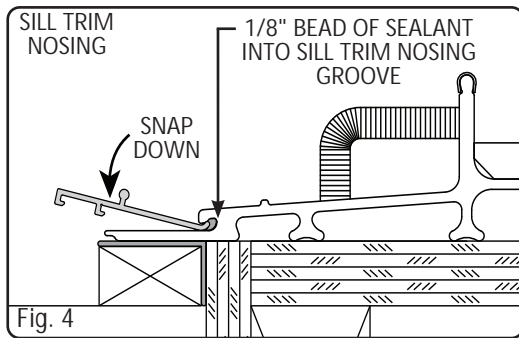
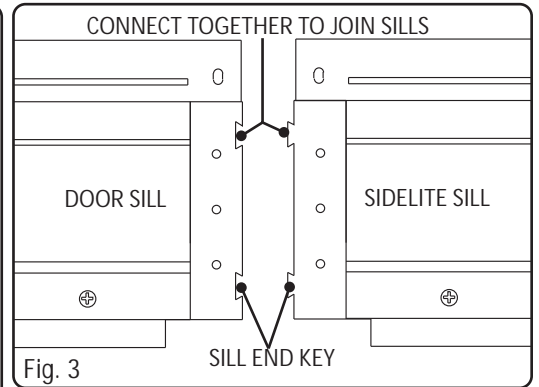
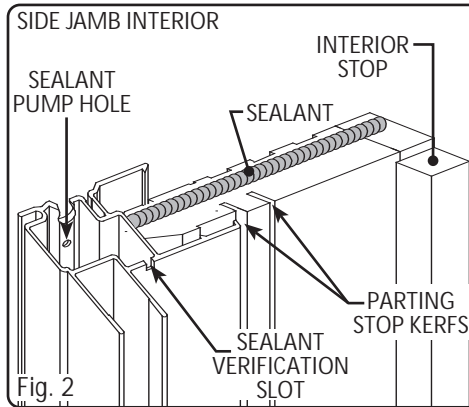
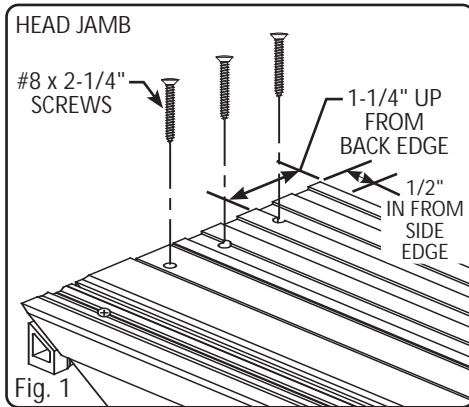

For 2-wide & 3-wide units:

- Dry fit each side jamb to the sill, aligning the edge of the side jamb with the end of the sill assembly. Drill 3/32" (2mm) pilot holes through the pre-drilled holes in the sill end keys and into the side jamb for each side.

- (Fig. 5) Pump corner key with silicone sealant until it squeezes out exit hole.

Pump end key with silicone sealant until it squeezes out along sill end keys.

- (Fig. 7) Apply a Sill Gasket to the sill end on each side jamb and where the mulled jambs sit (if applicable).
- (Fig. 8) Align and position each side jamb assembly with the end key onto the sill assembly. Secure them by fastening three #8 x 1-3/4" (44mm) screws through the holes in the sill and into each side jamb.
- The sill trim nosing has pre-drilled holes at both ends and beneath the mulled side jambs (if applicable). Secure it using #8 x 3/4" (19mm) screws through the holes, fastening into the side nosing and end key. Apply sealant to fill any gaps resulting from insufficient compression of the sill end key between the sill and side jambs.
- (Fig. 9 Top and Bottom) On the exterior of the frame, locate the sealant pump holes at the top of the side jamb on the jamb nosing, and the sealant verification slot on the opposite side of the frame near the screen track. Inject color-matching or clear sealant through the pump hole, filling the corner key until it appears at the verification slot. Wipe away any excess sealant that squeezes out.
- (Fig. 10) Attach a Nailing Fin foam corner seal to each top corner of the unit, where the side jamb and head jamb nailing fins meet (Fig. 8). The frame is now fully assembled and ready for installation.

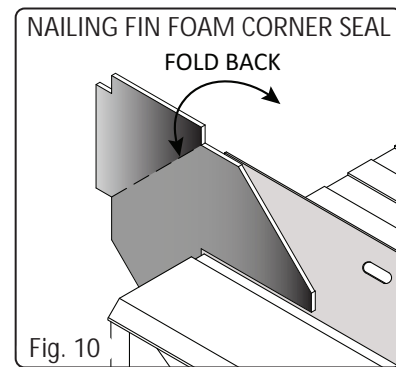
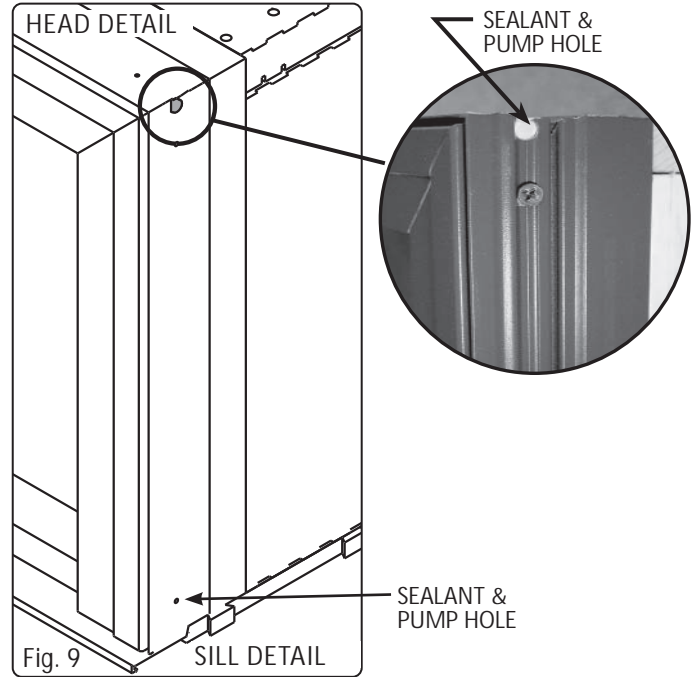
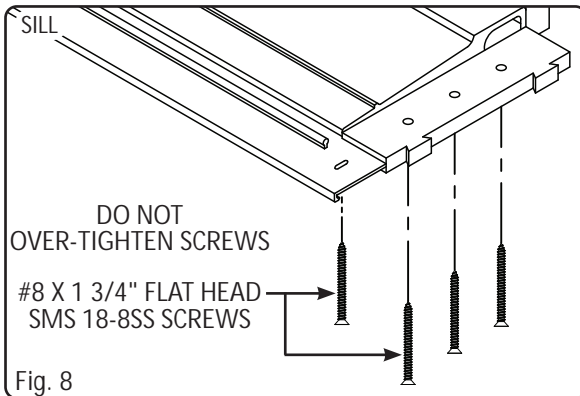
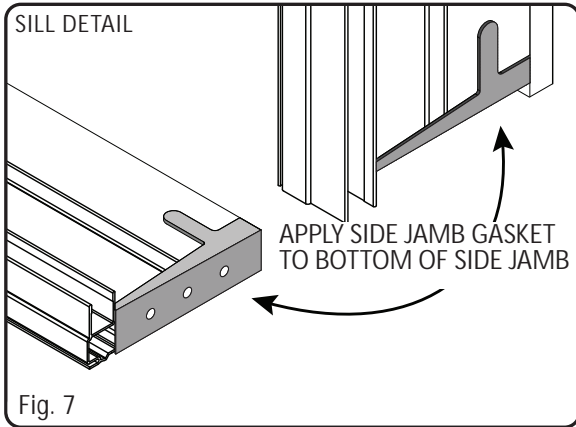

STATIONARY PANEL PREPARATION (if applicable)

The stationary panel sill filler is included in the loose parts kit. Ensure the dust block on the sill filler aligns with the same side as the interlock. Dry fit the sill filler into the bottom of the stationary panel.

Attach sill filler to stationary panel:

(Fig. 11) Apply a 3/16" (5mm) diameter bead of sealant on the top of the stationary panel sill filler along the entire length. Properly insert the stationary panel sill filler into the stationary panel bottom and secure it with the supplied #8 x 1-3/4" (32mm) Phillips pan head screws through the pre-drilled holes.

Set the stationary panel aside until stationary panel installation.

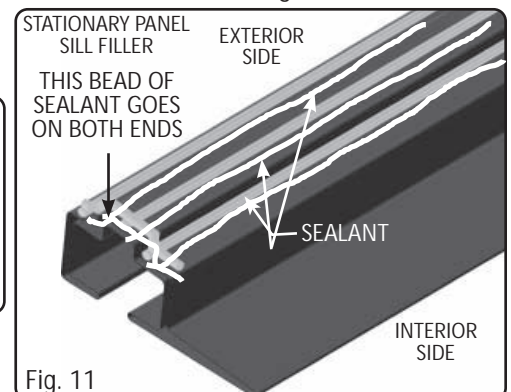
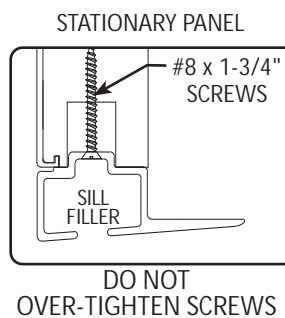

SIDELITE PANEL PREPARATION (if applicable)

The sidelite panel sill filler is shipped with the loose parts kit. The sidelite sill filler does not have a dust block. Dry fit the sill filler into the bottom of the sidelite panel now.

Attach sill filler to sidelite panel:

(Fig. 11) Apply a 3/16" (5mm) diameter bead of sealant on the top of the sidelite panel sill filler along the entire length. Properly insert the sidelite panel sill filler into the sidelite panel bottom and secure it with the supplied #8 x 1-3/4" (32mm) Phillips pan head screws through the pre-drilled holes.

SIDELITE PANEL INSTALLATION (if applicable)

Apply Sealant:

(Fig. 12) Apply a continuous 3/16" (5mm) diameter bead of sealant on the back of the screen channel on the head and side jambs along the full length of the frame as shown in (Fig. 12). Next (Fig. 13), apply a continuous 3/16" (5mm) bead of sealant on the full length of the sill as shown. The bead of sealant on the sill must join with the bead(s) of sealant on the back of the screen channel where the side jamb meets the sill (Fig. 12). Make sure the sealant on the head and sill joins the sealant on each side jamb.

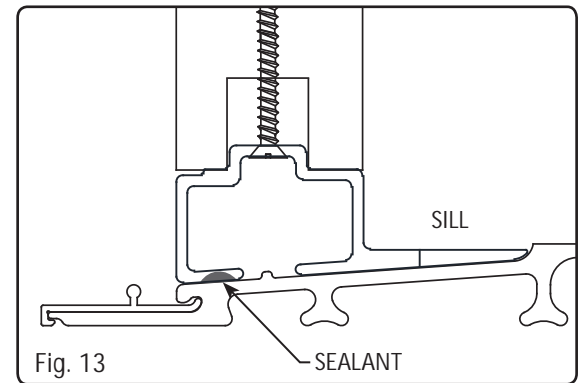
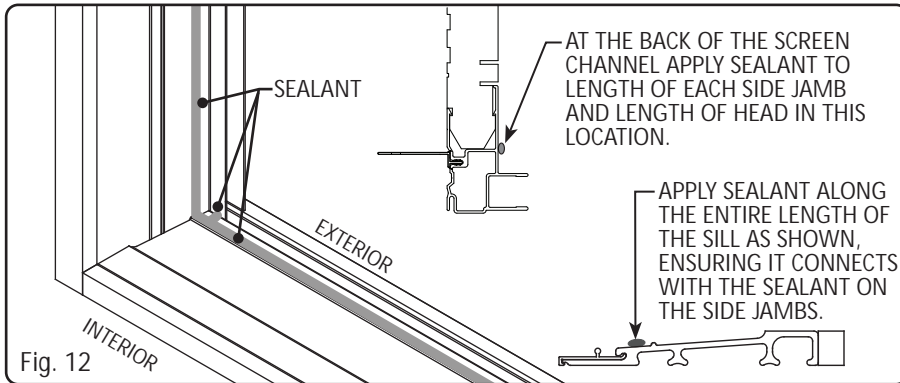

Install sidelite panel in frame:

To install the sidelite panel, work from the interior. Tilt the head of the panel into place, allowing it to rest against the screen channel. Rotate the bottom of the panel in towards the screen channel on the side jambs. The exterior of the panel should rest against the screen channel and the sill filler will sit in the bead of sealant applied to the sill. Apply pressure to the interior face of the panel to ensure the proper adherence of the sealant. There is enough sealant when you see squeeze out along the edges. Smooth the sealant edge to create a good seal. Clean up the excess sealant.

(Fig. 14 & 15) Mark screw placement at the head and sides: Head: 6" from each corner and 12" on center.

Sides: 19-11/16" from each corner and on center.

Place a shim between the frame and sidelite panel at each screw location.

Drill 3/32" (2mm) diameter pilot holes through the frame, shim and into the panel.

Use the supplied #8 x 3" PFH screws in the pre-drilled holes at the sides, then the head.

The sill filler will be secured to the sill once the frame is installed in the opening.

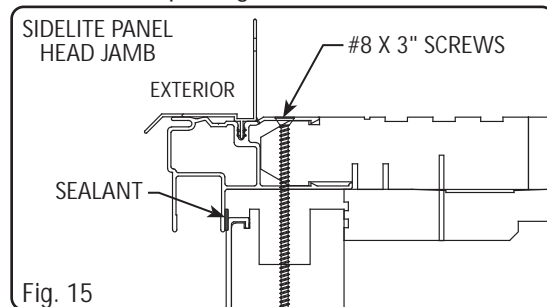
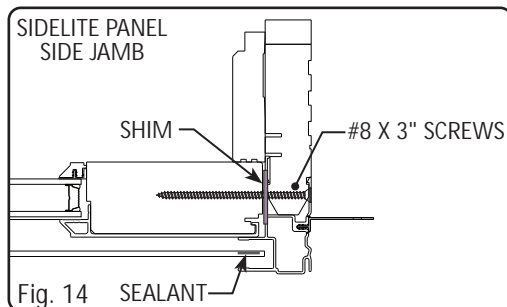

Interior Stops: (Excludes Through Frame Installation):

(Fig. 16) Interior stops can be installed if you are NOT using screw through the frame installation. Install the interior stops at the sides first, then the head. Secure the interior stops in place using 3/16" x 1-1/8" crown staples spaced 8-10" from the corners and on center. The sill interior stop will be installed once the frame is in the opening.

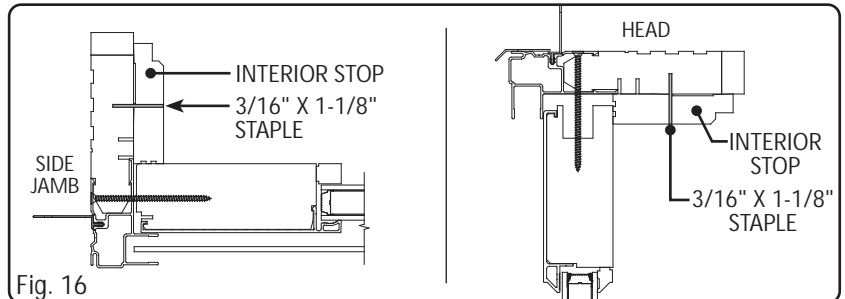

STATIONARY PANEL INSTALLATION (if applicable)

Place sealant on sill and side jamb:

(Fig. 17) On the sill, apply 3/16" (5mm) diameter beads of sealant as wide as the width of the stationary panel (Fig. 18). Ensure the interior bead includes a 2" (51mm) gap at its center. Next, apply a continuous bead of sealant along the back of the screen channel on the side jamb, running from the sill to the head jamb, as shown in (Fig. 16).

(Fig. 18) Apply a 3/16" (5mm) bead of sealant to the face of the dust block before installing the panel.

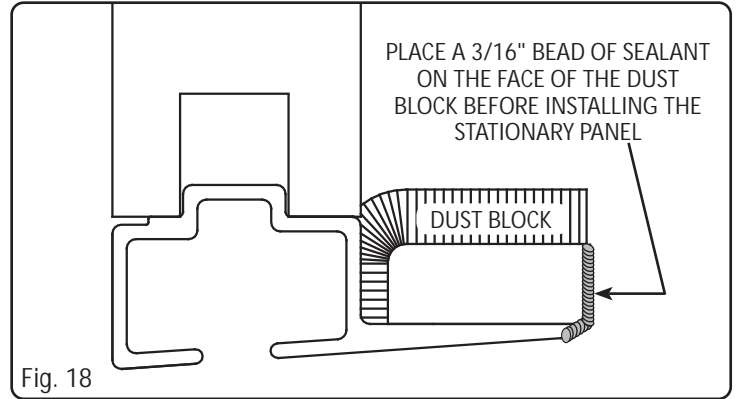
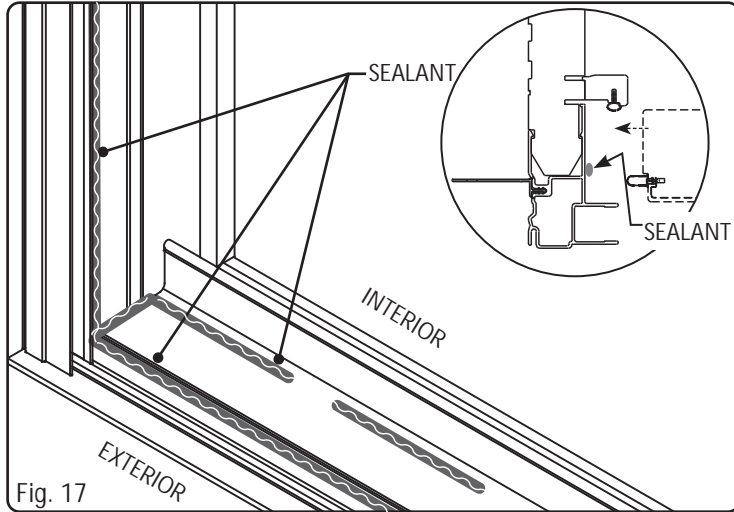

Install stationary panel in frame:

(Fig. 19) To install the stationary panel, work from the interior. Place the panel so the interior leg of the sill filler is against the sliding panel roller track. The vinyl interlock should be at the center of the unit. Tilt the head of the panel into place, allowing it to rest against the screen channel. Slide the panel snug up against the side jamb. Apply pressure to the interior face of the panel to ensure the proper adherence of the sealant. There is enough sealant when you see squeeze out along the edges, especially the exterior and interlock edges. Smooth the sealant edge to create a good seal. Clean up excess sealant. The stationary panel can be held securely in place by wedging a 2 x 4 (51mm x 102mm) between the side of the panel and the side jamb. Be careful not to damage the panel or the frame.

(Fig. 20) Drill 3/32" (2mm) diameter pilot holes into the head jamb assembly at each head bracket hole location. Secure the stationary panel head bracket using the supplied #8 x 1-1/4" (32mm) Phillips pan head screws.

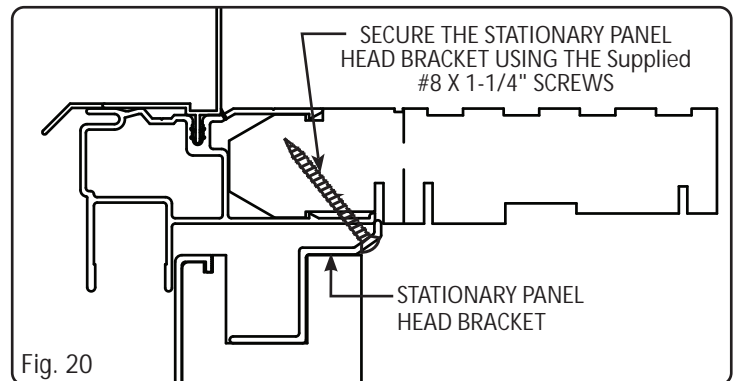
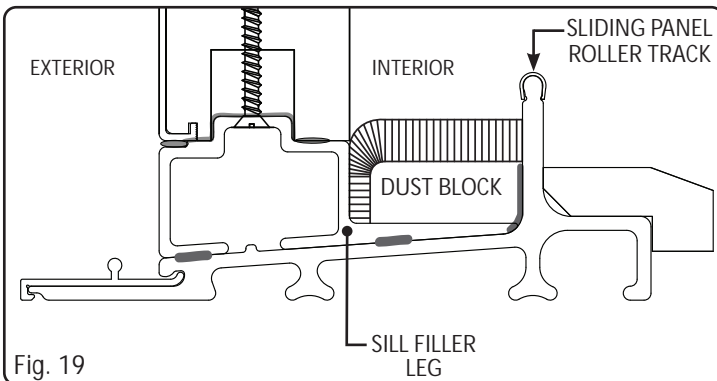

SELECT INSTALLATION TECHNIQUE

These techniques are general guidelines only, and may not be appropriate for all performance requirements. See the *Installation Anchor Calculator* on our website to help determine whether to use *Installation Clips* or the *Screw Through the Frame* method.

Kolbe recommends using **Technique #1 Installation Clips** is for units with exterior trim, and units in high wind pressure locations. **Technique #2, Screwing Through the Frame** may be required with some mullion situations.

- If using *Installation Clips Technique #1*, fasten the clips to the frame head and sides now. Use two #8 x 3/4" (19mm) Phillips flat head screws (supplied by others) per clip and follow the spacing determined by the *Installation Anchor Calculator*. For more information, see the instructions supplied with your Kolbe installation clips.

SELECT INSTALLATION TECHNIQUE NOTES & INSTRUCTIONS FOR CLIP & THRU FRAME FASTENING

Kolbe provides general installation techniques that may not suit all performance needs. **Technique #1 Installation Clips** is ideal for units with exterior trim and those in high wind areas.

Technique #2, Screwing Through the Frame may be necessary in some mullion scenarios. Our Installation Anchor Calculator can guide you on which technique to use. The calculator also helps determine clip spacing. For further details, refer to the instructions accompanying your Kolbe installation clips.

Factory-applied installation clips are available for a DP 20 rating. For higher DP ratings, additional clips must be applied in the field.

Apply Installation Clips: Installation Technique #1:

NOTE: The clips do not have specific left or right designations and are displayed in their shipping position.

To determine the clip size (PART A):

- ◊ Wall Framing 5-3/16" and smaller use the 6-5/16" clip.
- ◊ Wall Framing larger than 5-3/16" and less than 10-3/4" use 10 1/16" clip (Fig. 2).
- If using Installation Clips **Technique #1**, and they are not factory applied, fasten the clips to the frame head, sides, and sill now (Fig. 1).
- (Fig. 21) Use two #8 x 3/4" (19mm) Phillips flat head screws (supplied by others) per clip.
- Position the clips parallel to the jambs, Consult the instructions that came with the installation clips for spacing. Ensure the clips don't stick out past the frame edge.
- Put the first screw in the center hole. The second screw goes in the quarter-moon slot, facing the jamb's interior and aligned with the first screw.
- For units with multiple openings, apply clips to each opening as if it's a separate unit.
- For non-rectangular units, count clips as if the unit is rectangular. If a flat-top rectangular unit needs two clips, use two clips on a radius top unit's radius, keeping the same spacing. Measure the clip's position from the frame edge from the radius's start at the side jamb.
- Unit gets installed into the opening, attaching the clips to the wall with two #8 x 1-1/4" (32mm) Phillips flat head screws per clip.

NOTE: The interior (mull) sides receive no clips and are site installed. Mull end anchors are by others. See *Flashing Information* for additional installation information.

(Fig. 22) Install the supplied #8 x 3" (78mm) Phillips Flat Head screws through the outside of the frame and into the stationary panel evenly spaced on center down the side jambs. (Use three screws for a 6-6 or 6-8 unit height and four screws for an 8-0 unit height).

(Fig. 23) Apply the wood head parting stop with 18 GA x 1-1/2" brad nails (supplied by others). Repeat for side jamb parting stops.

Apply sealant to the pre-drilled holes in the stationary panel sill filler. Using the supplied #8 x 5/8" (44mm) Phillips pan head screws, fasten the sill filler to the sill. Remove the 2 x 4.

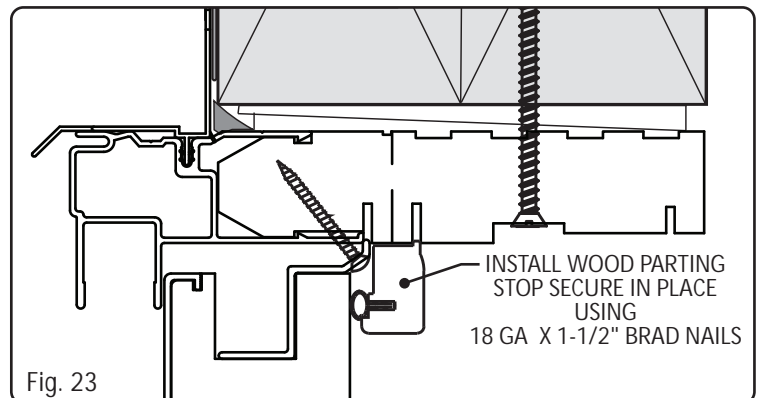
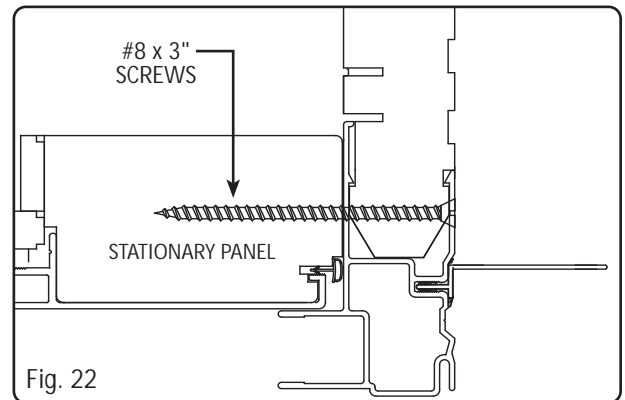
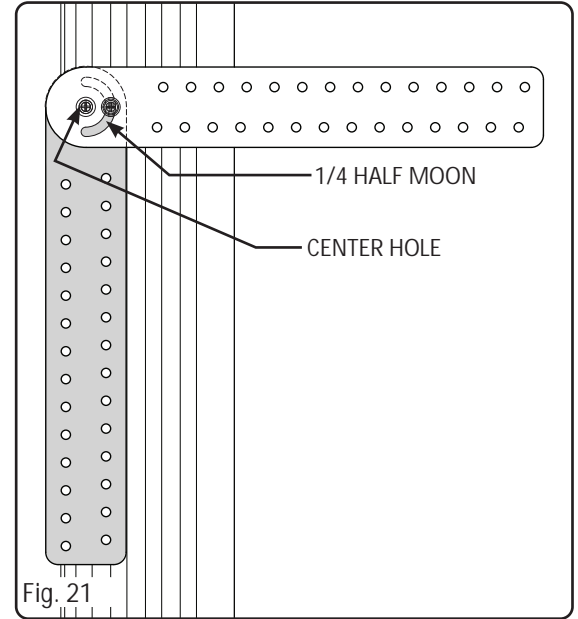
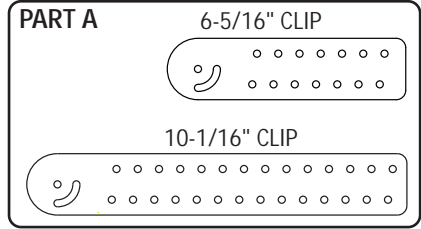

SEALANT AND FLASHING

Kolbe recommends adhering to ASTM E2112 standards for proper sealing and flashing of exterior doors. Ensure a minimum gap of 3/8" (10 mm) between the door frame and the rough opening structure to allow for adequate sealing. Establish a continuous and effective seal between the door and the building exterior.

For detailed guidance, refer to our *Sealant Information* and *Flashing Information* pamphlets.

These resources are available through your Kolbe window and door supplier, or you can download them at <http://www.kolbewindows.com>.

Install Sill Pan (if applicable):

Where applicable, Kolbe recommends the use of a sill pan when installing windows and doors. Follow ASTM E2112 standards when making and installing the sill pan.

When using a sill pan the following must be met:

- The sill pan flashing must be integrated with the water resistant barrier and other flashing materials.
- Sill pan flashing shall not be sloped toward the interior.
- The height of the rear upturned leg (back dam) of the sill pan must be appropriate for the product being installed on.
- For more information on Sill Pan application, see *Flashing Instructions* on the Kolbe website at www.kolbewindows.com.

Apply sealant to unit: Based on your unit configuration for proper sealant placement.

Ultra Series Units with Nail Fin (Fig. 23) or VistaLuxe WD LINE Units with Brickmould (Fig. 24):

- Apply two 3/16" (5mm) continuous beads of sealant around the perimeter on the backside of the nail fin (Fig. 24). One bead is to be placed where the fin meets the frame and the second placed 3/8" (10mm) from the edge of the nailing fin.
- Apply sealant to the edges of the foam corner seal, (Fig's 25 & 26).

NOTE
NAIL FIN UNIT SHOWN, SEALANT FOR WOOD BRICKMOULD UNITS PLACEMENT IS THE SAME

Units with Brickmould only (Fig. 25):

Apply two 3/16" (5mm) diameter continuous beads of sealant around the perimeter on the backside of the brickmould.

Next, apply sealant to the edges of the foam corner seal.

Units with Nail Fin & Brickmould (Fig. 26):

Apply three 3/16" (5mm) continuous beads of sealant around the perimeter on the backside of the brickmould and nail fin. Next, apply sealant to the edges of the foam corner seals.

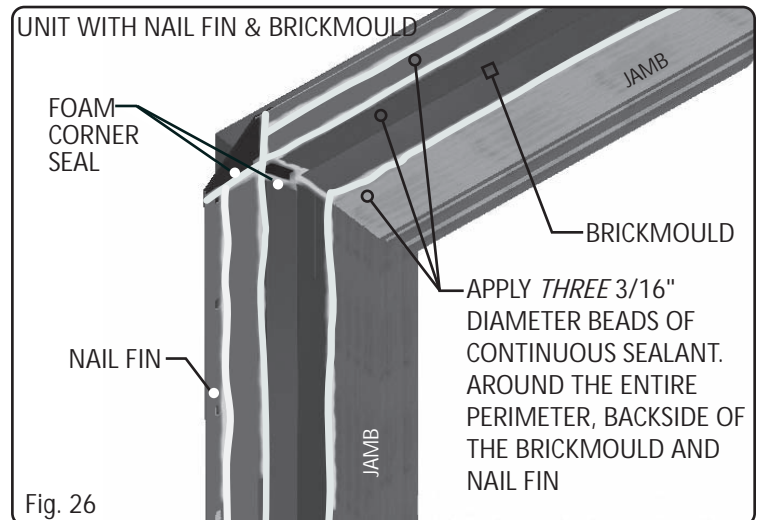
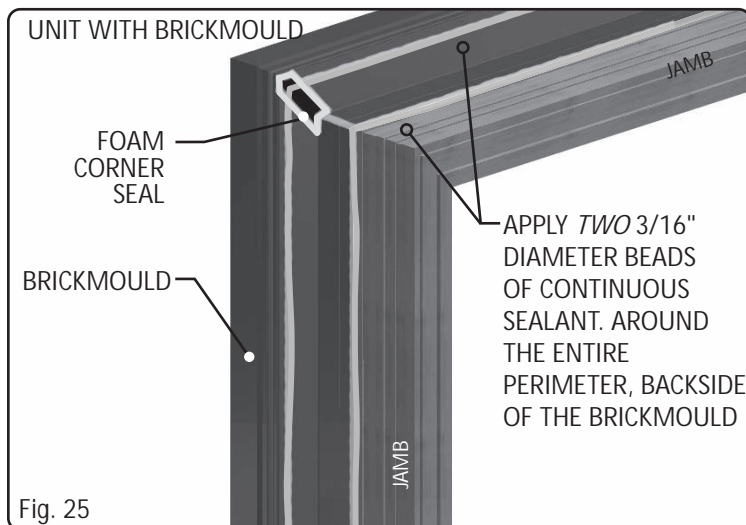
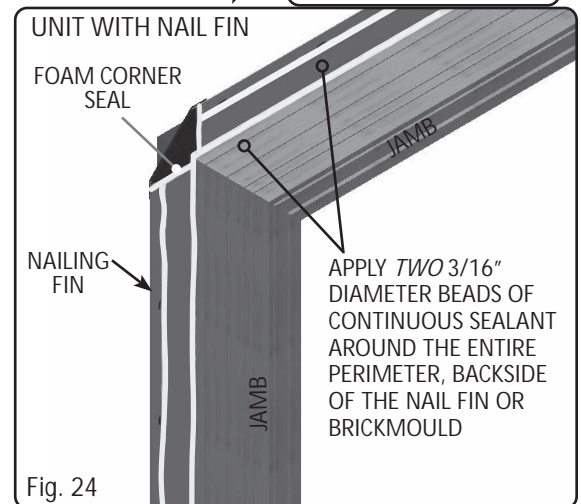

⚠ IMPORTANT

Be sure all points where the casing meets the side jamb(s) and sill nosing are sealed on the backside of the unit.

Apply Sealant to Rough Opening Sill (Fig. 27):

Run two 3/8" (10mm) diameter beads of sealant across the entire width of the subfloor and up each side jamb a minimum of 12" (305mm), allowing the sealant to pool in the corners. Run the first bead 1/2" (13mm) in from the exterior face of the wall, and run the second bead 1-1/2" (38mm) in from the first bead.

INSTALLATION TECHNIQUE 1: INSTALLATION CLIPS

NOTE: If using screw through the frame (sides) installation, skip to the next section titled "INSTALL UNIT IN OPENING BY SCREWING THROUGH THE FRAME".

Place Unit in Rough Opening:

From the exterior, tilt the unit, sill first into the opening. Center the unit and press the brickmould/casing or nailing fin against the sheathing.

Temporary Fastening for Units with Nailing Fin (units without nailing fin, skip to checking for square and plumb):

(Fig. 28) Tack the unit in place using one 1-1/2" (38mm) or longer galvanized roofing nail (supplied by others) in the first pre-punched hole from one of the top corners/ends of the nailing fin to tack unit in place. Once the unit is tacked in place, ensure it is plumb, level, and square within the opening. Then, insert 1-1/2" roofing nails into every third hole (approximately 10-1/2" or 267mm apart) along the head and sides. Be cautious not to drive the nail heads in too far, as this may cause compression and warping of the nailing fin.

Checking for Square and Plumb (Fig. 29):

Check that the unit is square, measure both diagonals from the interior, the measurements must be within 1/16" (2mm) of each other.

The height of the frame at the center must be the same as the height at each end.

Add shims if necessary to square the unit in the opening.

Check for plumb, using a plumb bob and level between the head and sill.

Shimming (Fig. 29):

At a minimum, place shims along the head and side jambs 4" (102mm) from the corners/ends and every 12" (305mm) between. Place one shim above each installation clip between the frame and rough opening.

Shimming ensures correct margins/reveals, parallel jambs, a level unit, and proper operation.

Do not bow the jambs by over shimming.

Securing the Sill (Fig. 29):

In order to secure the sill, you must first remove the screws at each end of the oak threshold and every other screw in between (remove all screws on High Performance/Impact units).

French doors (2-wide doors) should have 2 screws fastened into the oak threshold at the center of the sill.

Drill a 3/16" (5mm) clearance hole through the existing hole locations. Ensure the hole passes through the oak threshold and sill, stopping short of the underlying floor system. Drill a 7/64" (3mm) lead hole through the clearance hole into the underlying floor system. Drill a 3/16" (5mm) hole when anchoring sill into a concrete floor.

Place a dab of sealant into each screw hole prior to installing screws, in order to prevent any penetration of water that may get on the sill. Complete by installing a #10 x 3" (78mm) Phillips flat head stainless steel screw into each of the pre-drilled holes.

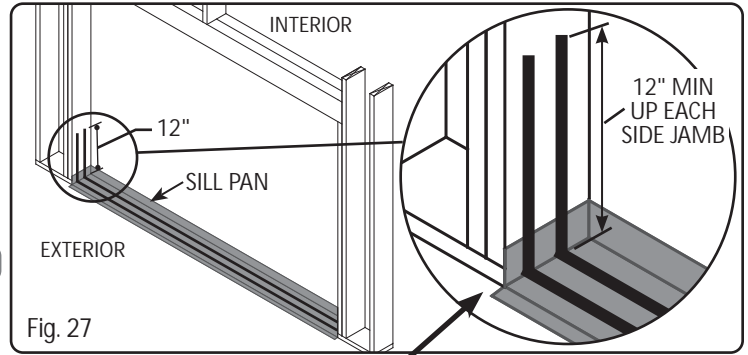

Fig. 27

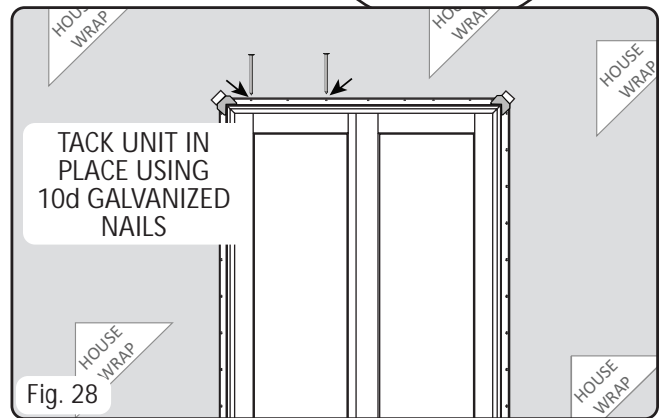
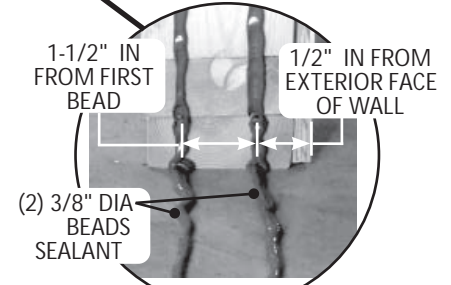

Fig. 28

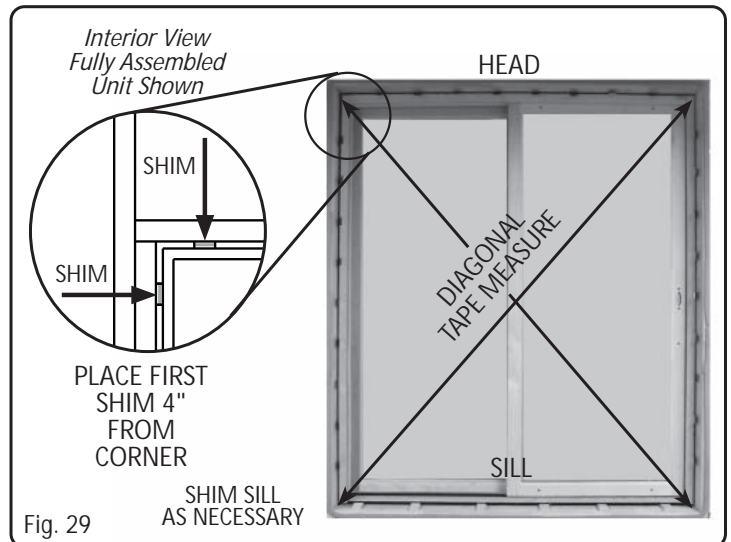
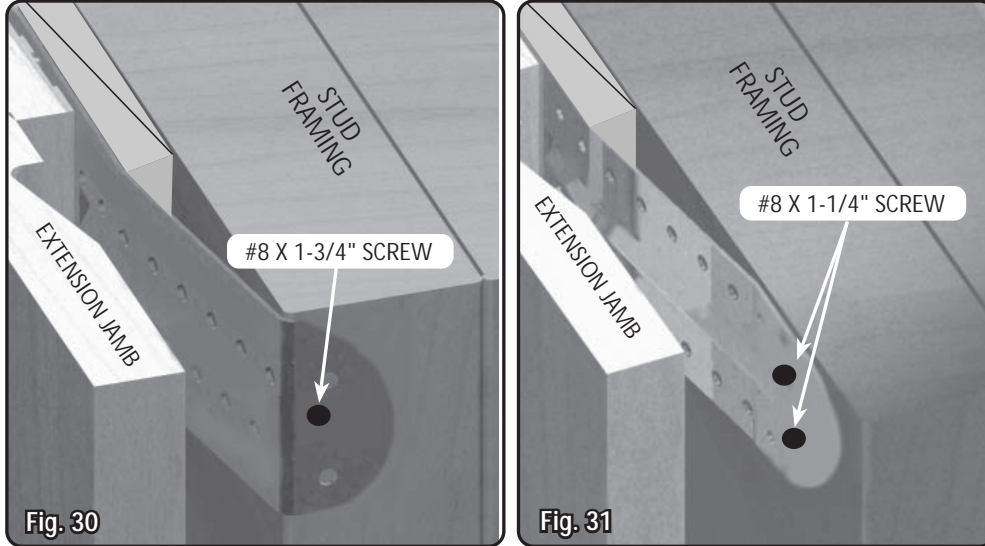

Fig. 29

Secure unit in opening (Fig 30 & 31):

Place a shim between the frame and rough opening above each installation clip to prevent bowing. Starting with an interior upper corner, hammer bend the clip(s) as shown in (Fig. 30) or do a face mount as shown in (Fig. 31) around the rough opening frame and fasten with one # 8 x 1-3/4" (44mm) SMS (supplied by others) or two 8d common nails (supplied by others) at a 20° angle through the pre-punched holes at the hammer-bend within 1/8" of buck corner or two #8 1-1/4" (32mm) SMS (supplied by others) for face mounted clips. Continue around the perimeter, making sure the jambs are straight and the unit is square.



CAUTION

Do not over-tighten the installation clips.
Over-tightening installation clips may distort the frame components and break the sealant joints.

INSTALLATION TECHNIQUE 2: INSTALL UNIT IN OPENING BY SCREWING THROUGH THE FRAME (ALTERNATE METHOD)

Placing the Unit in the Rough Opening:

From the exterior, tilt the unit sill-first into the rough opening. Center the unit and press the brickmould or nailing fin firmly against the sheathing.

Temporary Fastening for Units with Nailing Fin:

(For units without nailing fin, skip to the "Checking for Square" section.)

(Fig. 27) To hold the unit temporarily in place, insert one 1-1/2" (38mm) or longer galvanized roofing nail (not supplied) into the first pre-punched hole near each corner/end of the nailing fin. Ensure the unit is plumb, level, and square within the opening. Then, drive 1-1/2" roofing nails into every third hole (approximately 10-1/2" [267mm] apart) along the head and sides. Avoid driving the nail heads too deep, as this can compress and distort the nailing fin.

Shimming:

(Fig. 28) Place shims along the head and side jambs at a minimum distance of 4" (102mm) from the corners/ends, and every 12" (203mm) in between. For screw-through-frame installations, place a shim behind each marked screw location between the frame and rough opening. Proper shimming ensures correct margins, parallel jambs, a level unit, and smooth operation. Be cautious not to over-shim, as this can cause the jambs to bow.

Checking for Square:

(Fig. 29) From the interior, measure both diagonals of the unit to ensure it's square. The measurements should be within 1/16" (2mm) of each other. Also, verify that the frame's height at the center matches the height at both ends, and that the margins around the door are even. Use shims as needed to square the unit in the opening.

Securing Side Jambs:

Determine which jambs need to be secured based on your unit's configuration. Possible configurations include active/fixed, fixed/active, active/fixed/sidelite, fixed/active/sidelite, sidelite/fixed/active, or sidelite/active/fixed. The steps below cover securing each type of side jamb.

For the Active Panel Side Jamb (viewed from the exterior):

1. (Fig. 32) Secure the active panel side jamb by screwing through the frame behind the parting stop, towards the interior of the unit. From the interior edge of the parting stop, measure 3/8" (10mm) towards the interior, and mark screw locations 8" (203mm) from the top and bottom corners. Use the **Installation Anchor Calculator** to determine additional screw spacing.
2. Insert shims between the unit and the rough opening framing behind each marked screw location. Ensure the sill is straight and level, and that the side jambs are plumb and the head jamb is level.
3. On the active panel side jamb, drill pilot holes using a 9/64" (4mm) drill bit through the side jamb, shims, and into the rough opening framing.
4. Apply sealant into the pilot holes, then insert #10 x 2-1/2" (64mm) flat head screws (not supplied). Tighten the screws until the heads are flush with the side jamb for proper installation and performance of the active panel.

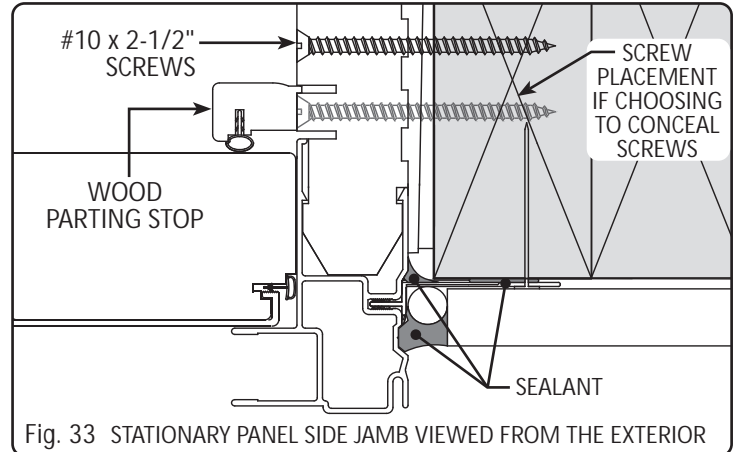
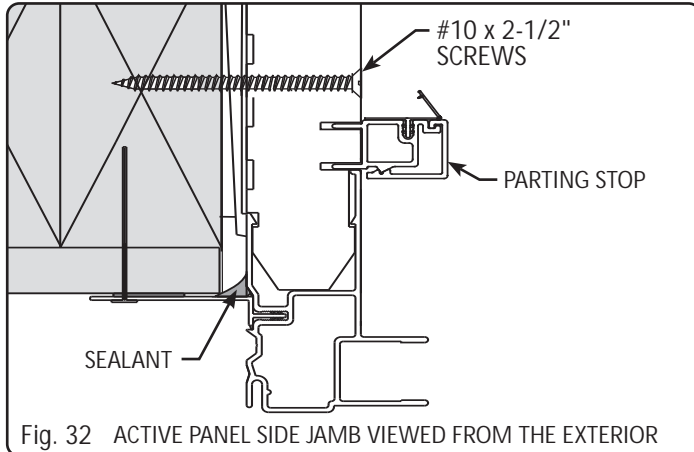

Securing stationary panel side jamb (as viewed from the exterior)

- (Fig. 33) The stationary panel side jamb must be screwed through the frame in back of the parting stop, towards the interior of the unit. From the interior edge of the parting stop, measure 3/8" (10mm) towards the interior and 8" (203mm) from the top and bottom corners to mark screw locations. Mark additional locations at the spacing required by the *Installation Anchor Calculator*.
- Place shims between the unit and the rough opening framing behind each marked hole location. Double-check the unit to ensure the sill is straight and level. Plumb the side jambs and level the head jamb.
- Continue to the side jamb of the stationary panel, drill pilot holes through the side jamb using a 9/64" (4mm) drill bit. Countersink these holes with a 13/32" (10mm) drill bit. Extra long bits may be needed to avoid damaging installed panel.
- Squeeze sealant into the holes and insert #10 x 2-1/2" (64mm) flat head screws (supplied by other). Snug the screw heads flush with the side jamb. If you would like the screw heads concealed you will be required to remove the wood parting stop and place the screws under it and then re-apply the wood parting stop using finish nails to secure it in place. The screw heads must be flush with the side jamb for proper application of the wood parting stop. (Removing the wood parting stop may cause damage and require replacement.)

Securing sidelite panel side jamb (if applicable):

- (Fig. 34) Remove the interior stops from the sill and the side jamb next to the rough opening, set aside (if applicable).
- Place shims between the unit and the rough opening framing behind each marked hole location. Double-check the unit to ensure the sill is straight and level. Plumb the side jambs and level the head jamb.
- Place the screws through the side jamb and into the rough opening, as shown in (Fig. 34).

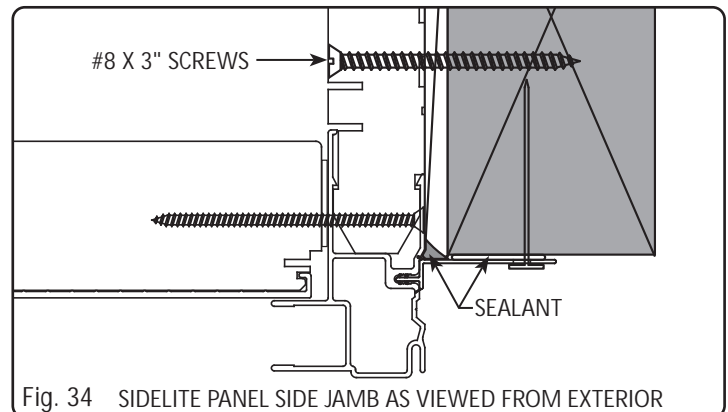

Securing head of active/fixed unit:

- (Fig. 35 & 36) To secure the head, remove the wood sash retainer bracket (1-3/4" panels) or aluminum head track guide (2-1/4" panels). Set aside the sash retainer bracket or aluminum head track guide for now, it will be re-installed later.
- In the retainer bracket kerf, mark hole locations 4" in from each end and 12" on center.
- Place shims between the unit and the rough opening framing behind each marked hole location. Double-check the unit to ensure the sill is straight and level. Plumb the side jambs and level the head jamb.
- Install #8 x 3" (78mm) flat head screws (supplied by other). The longer screws will penetrate into the shims and rough opening framing and properly secure the unit.

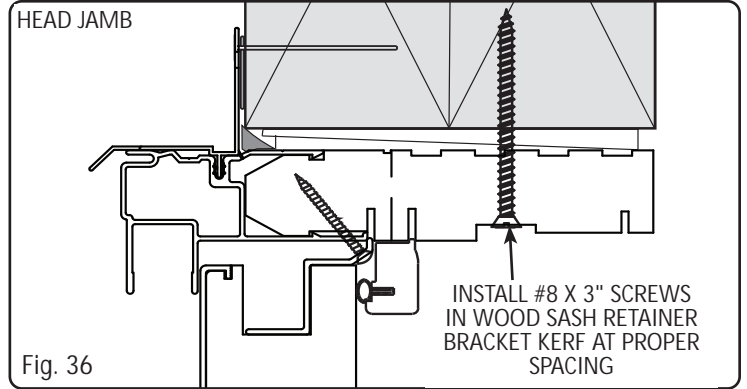
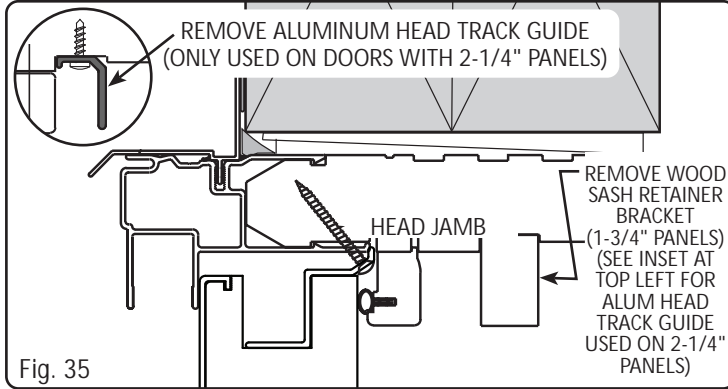

Securing head of sidelite (if applicable):

1. Remove the head interior stop and set aside.
2. Mark hole locations 4" in from each end and 12" on center.
3. Place shims between the unit and the rough opening framing behind each marked hole location.
4. (Fig. 37) Install #8 x 3" (78mm) flat head screws (supplied by other) 4" in from each end and 12" on center as shown in (Fig. 37). The longer screws will penetrate into the shims and rough opening framing and properly secure the unit.

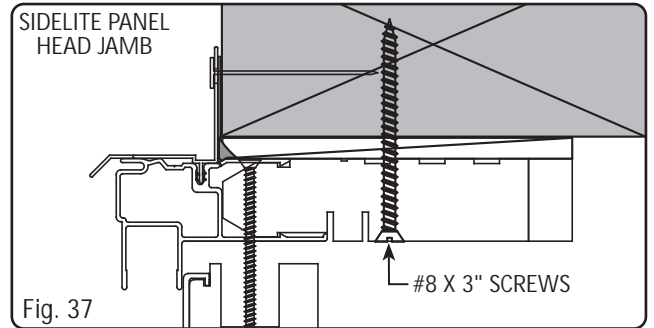

SECURING THE SILL

1. (Fig. 38) The interior oak sill stop was secured with short screws for shipping purposes. Remove and discard these screws.
2. Using a 3/16" (5mm) drill bit, enlarge the existing holes in the oak interior sill stop, continuing through the fiberglass sill. Take care not to drill into the floor beneath.
3. Through the clearance holes, drill 7/64" (3mm) pilot holes into the underlying floor.
- *Note for Concrete Sub-floors:* Use a drill bit sized appropriately for the fasteners you intend to use (not included).
4. Seal each screw hole with an appropriate waterproof sealant to prevent moisture intrusion.
5. Secure the sill stop using the provided #8 x 3" (76mm) Phillips flat head stainless steel screws.

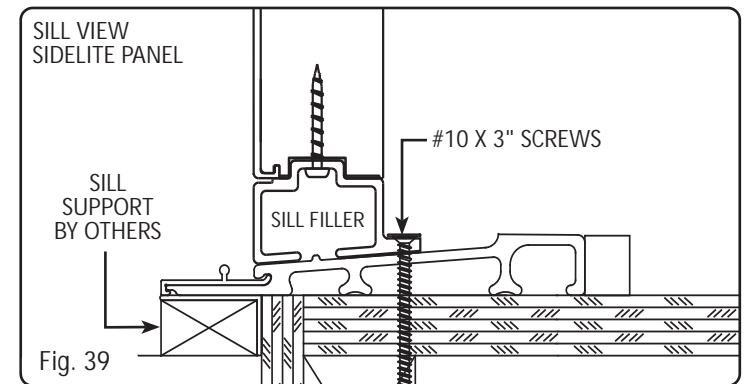
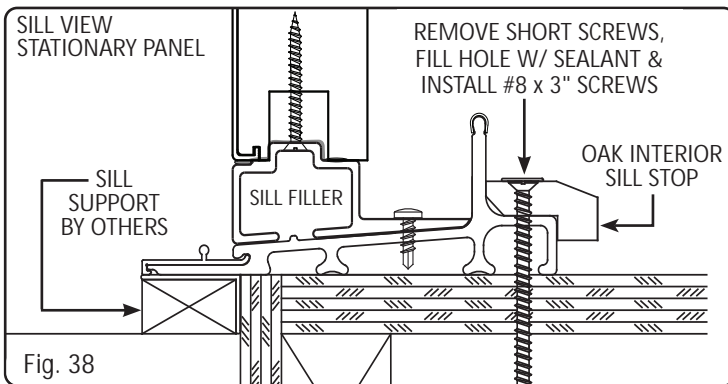

3-Wide Units: (Fig. 39) Remove the temporary screws from the sidelite sill filler (if applicable). On the sidelite sill interior use a 9/64" drill bit to pre-drill the existing holes. Apply sealant to each screw hole to prevent penetration of water that may get on the sill. Secure the sidelite sill to the sub-floor using the supplied #10 x 3" (76mm) Phillips flat head screws.

Sidelite Interior Stops (if applicable):

(Fig. 40) Install the sidelite interior stops. Apply the side stops, then the head and lastly the sill. Secure the interior stops in place using 3/16" x 1-1/8" crown staples spaced 8 - 10" from the corners and on center. At the sill apply square glazing bead as shown. Secure with 1" 21 gauge headless pin nails spaced 8 - 10" in from corners and on center.

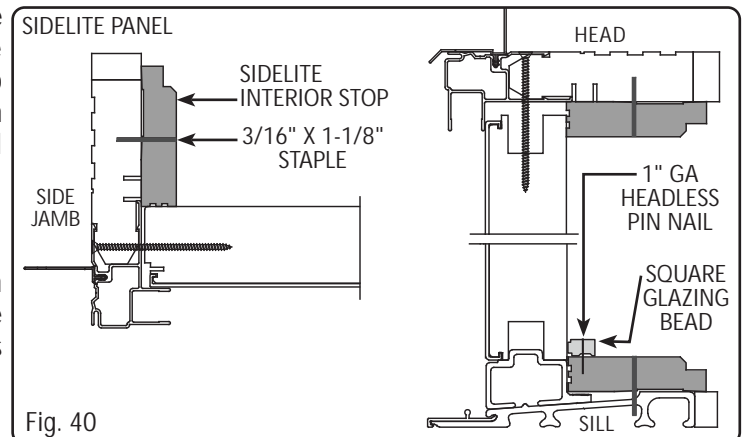

FRAME PREPARATION FOR ACTIVE PANEL

(Fig. 41) On the active side of the frame at the head, run a bead of sealant in the parting stop kerfs. Place the parting stop base (weatherstrip side faces the interior) into the kerfs. Secure the parting stop base using the supplied #6 x 1-1/2" (29mm) pan head screws to screw through the pre-drilled holes and into the head jamb. Attach the parting stop cap by snapping it onto the parting stop base as shown in (Fig. 39).

Place the parting stop foam plug in the gap between the wood parting stop and metal parting stop above the interlock on the stationary panel.

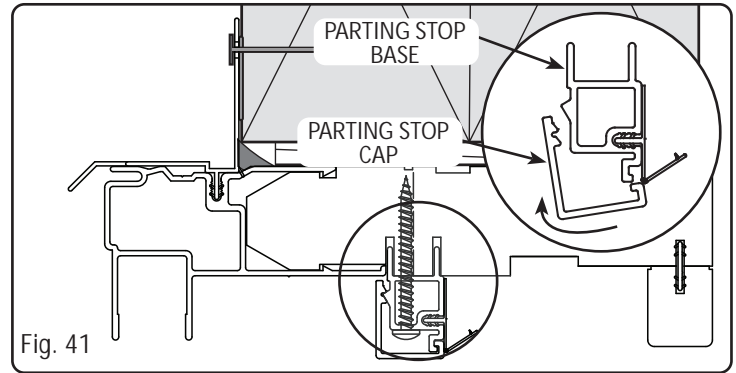

Fig. 41

UNITS WITH 2-1/4" PANELS

(Fig. 42) Make sure the sill is level; shim under the bracket if required to make the sill level. In the empty holes at each end of the bracket, you will need to use a 3/32" drill bit to pre-drill into the frame. When done pre-drilling the holes, install the supplied #9 x 3" PFH screws into those holes.

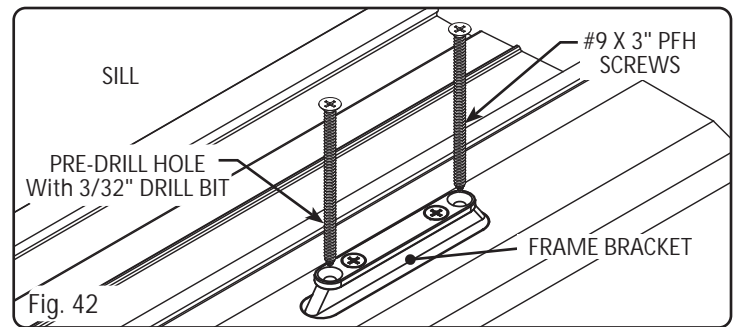

Fig. 42

ACTIVE PANEL INSTALLATION

(Fig. 43) Remove the bottom rail weatherstrip shipping support from the active panel by sliding it out from the end. With the glazing bead side of the active panel facing the interior of the building, position the active panel in front of the stationary panel, tilting the active panel slightly and resting the rollers, located in the base, on the sill roller track. Set the sash retainer bracket in the groove at the top of the active panel. Tilt the head of the panel into place, allowing it to rest against the head parting stop. Slide the panel over to the active side. The vinyl interlock will now be at the center of the unit.

(Fig. 44) Position the sash retainer bracket or aluminum head track guide in the groove on the head jamb. Slide the sash retainer bracket or aluminum head track guide over so it is flush against the stationary panel side jamb (there will be a gap on the active panel side). Install the supplied #10 x 1-3/4" (44mm) Phillips flat head screws into the pre-drilled holes for the wood sash retainer bracket or #8 x 3/4" screws into the pre-punched holes for the aluminum head track guide. Slide the panel back over to the stationary side and install screws in the sash retainer bracket or aluminum head track guide on the active side.

(Fig. 44) Install the wood interior head stop by pressing it into the kerf closest to the interior of the unit. Complete the panel installation by inserting the panel bumper between the head parting stop and the wood sash retainer bracket. Place one end of the panel bumper against the stationary side jamb. Secure the panel bumper in place using two 1-1/2" brad nails (supplied by other).

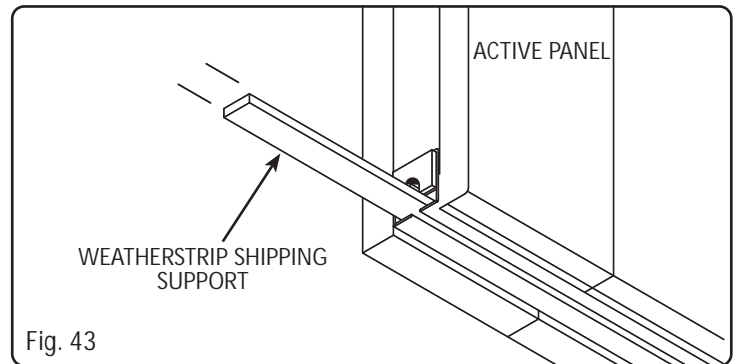

Fig. 43

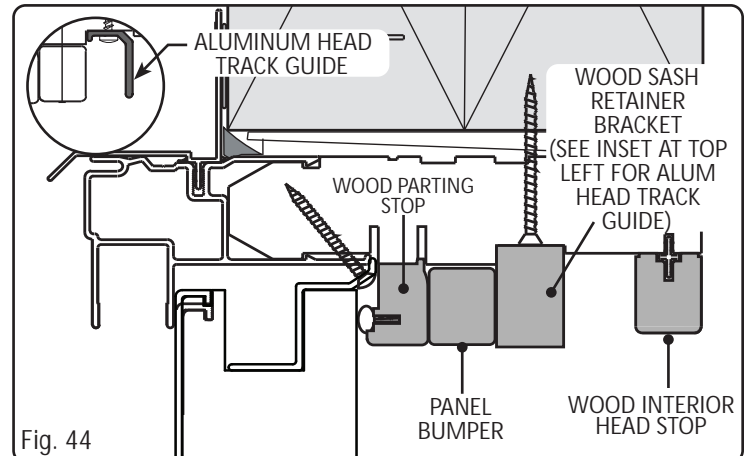
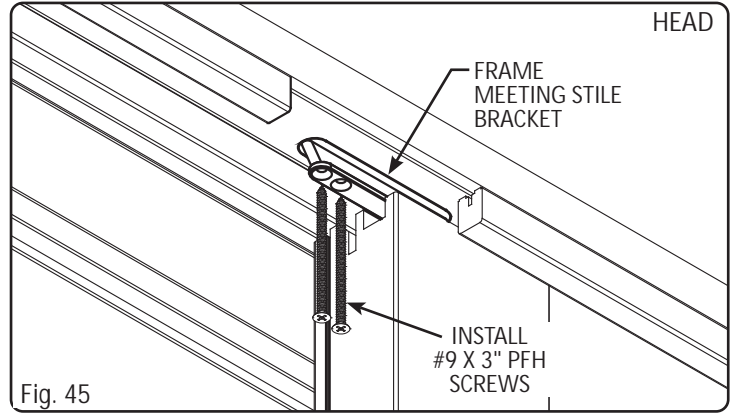

Fig. 44

Install the Head Frame Meeting Stile Brackets (Fig. 45):

- To do this, close the panel all the way.
- Slide the head frame meeting stile bracket into the pre-routed head jamb.
- The bracket has 4 holes, only two are visible. Only the visible screw holes will be used.
- Pre-drill the holes using a 3/32" drill bit.
- Install #9 x 3" PFH screws into the visible holes.
- Shim between head jamb and the rough opening as required to maintain a level head jamb.



ADJUSTMENTS

(Fig. 46) For 1-3/4" Panels: The panel rollers may require adjustment for proper operation of the unit. Slightly open the active panel, just enough to view the weatherstrip and side stop, and inspect the margin for consistency.

If adjustment is needed, remove the panel adjustment caps from the bottom rail. For adjustments, insert a standard head screwdriver. For 2-1/4" panels, use a 5/32" T-handle Allen wrench (hex key) to adjust the panels. Turn right to move panel up and left to move the panel down into the opening and turn to raise or lower one corner of the panel. After making the adjustments, replace the panel adjustment caps to cover the holes. To raise or lower a corner of the panel. After adjusting, plug the holes with the supplied caps.

Install the meeting stile panel brackets (Fig. 47). The head and sill meeting stile brackets are different so be sure to select to correct one for each application.

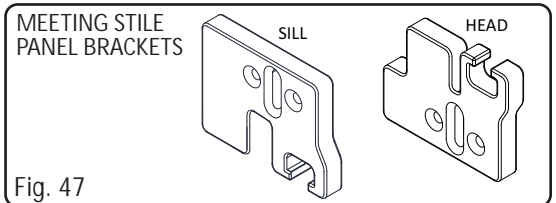
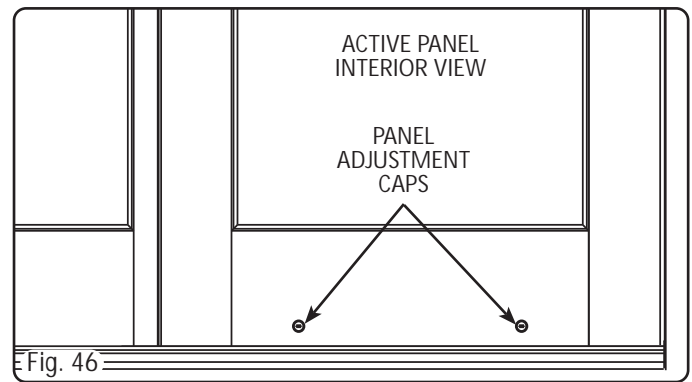

Head & Sill Panel Bracket Application (Fig. 48 & Fig. 49): Position the panel bracket so it is centered on the frame bracket. Using a 1/8" drill bit, pre-drill the center hole through the slot. Secure the bracket by installing a #9 x 2" screw into the adjustable center slot. If the bracket shifts during tightening, realign it. Ensure smooth panel operation with no binding between the frame and the panel bracket. Finally, pre-drill and install #9 x 2" screws into the remaining two holes.

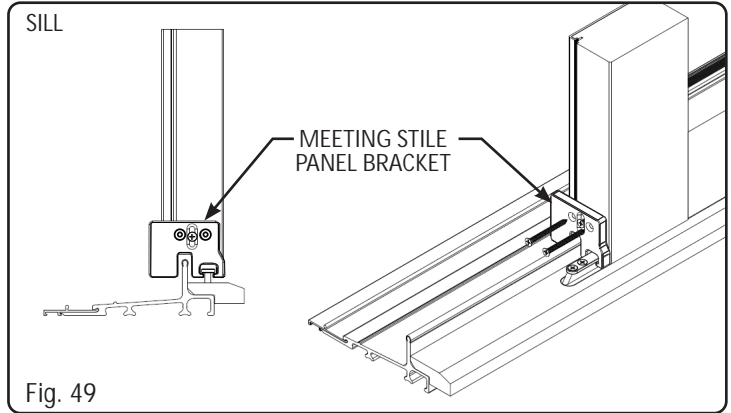
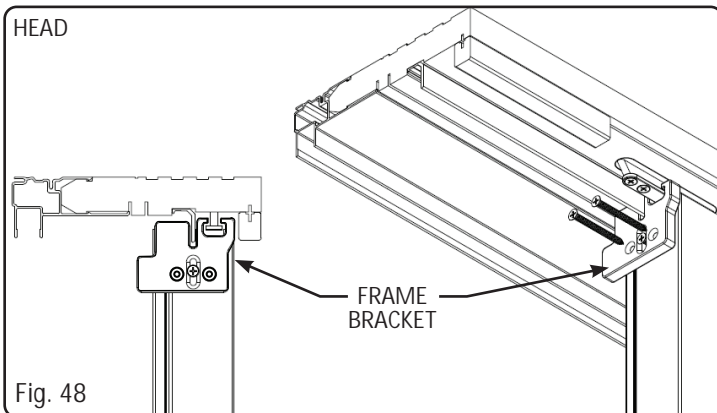

ADDITIONAL FASTENING

Enhanced Strength and Security Installation:

To increase strength and security, replace the screws in the lock keeper on the side jamb with longer ones that penetrate the side jamb, shims, and deep into the rough opening framing. First, remove the existing screws from the lock keeper. Insert a shim between the frame and rough opening behind the lock keeper. Drill 3/16" (5mm) clearance holes through the existing screw holes, 1-1/16" (27mm) deep. Then, drill 7/64" (3mm) pilot holes just into the rough opening framing. Finally, replace the removed screws with the supplied #8 x 2-1/2" (64mm) Phillips pan head screws.

COMPLETE THE EXTERIOR

Drip Cap Installation (Fig. 50):

A drip cap must be installed/ applied in order to direct water away from the door. (This is required by most building codes and a requirement of proper installation for all Kolbe products.)

1. If a drip cap has not been applied, apply now.
2. Seal the side edges of the drip cap to the door and between the drip cap and the exterior sheathing.
3. Seal between the drip cap and the exterior sheathing.
4. When you apply building wrap over exterior sheathing, ensure that you also secure and seal the wrap to the drip cap.
5. Apply a 3/16" (5mm) diameter bead of sealant where the sill trim nosing meets the brickmould edge.
6. Smooth the sealant to ensure a proper seal.
7. If necessary, install a support block beneath the sill for added stability.

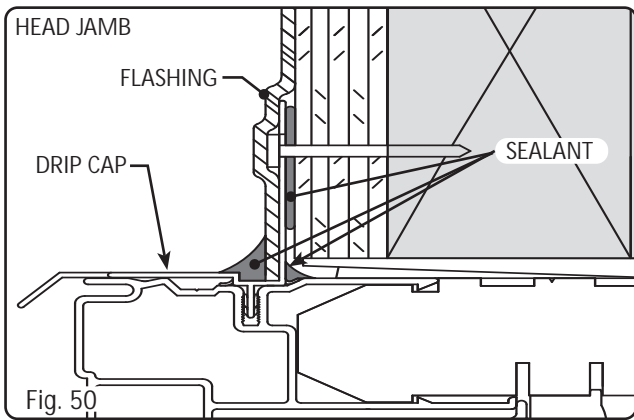

⚠ IMPORTANT

Ensure there is a minimum 1/4" (6mm) expansion joint between the window perimeter and any exterior facing materials such as brick, stone, marble, or concrete. This gap allows for structural movement or settling, which could impact the unit's operation.

INSULATION & INTERIOR CASING/TRIM

Kolbe recommends installing fiberglass insulation in the void created by the outer perimeter of the door frame and rough opening members. Using a putty knife, loosely fill the entire depth of the gap with insulation. (Foam insulation may be used, but it must be a low expansion type foam for window and door installation. Use of any foam other than low expanding foam will void the warranty. Next, apply the interior casing.

⚠ CAUTION

Over-packed insulation can lessen the insulation effectiveness and distort the frame, resulting in poor panel operation. If you are using a foam type insulation, it must be a low expansion type foam for window and door installation and used in conjunction with fiberglass insulation. Follow the manufacturer's instructions for proper application of the foam.

INTERIOR FINISHING

Interior: Finish bare wood interiors within 90 days, using a top quality stain and top coat. On factory primed interiors, apply a quality top coat system.

⚠ IMPORTANT

Avoid getting finishing products on any vinyl components and weatherstripping.

REMOVAL OF PROTECTIVE FILMS

All factory applied protective film affixed on the face of the door frame and/or sash metal must be removed within six (6) months. Additionally, the door glass protective film (Preserve Film) is required to be removed within six (6) months from the surface of the glass.

MAINTENANCE TIPS / PROCEDURES

Inspect your Kolbe products periodically/yearly to see if the exterior sealants and/or finishes have any gaps, cracks or signs of damage and deterioration. Any cracks must be caulked immediately with a high quality sealant, to maintain the seal integrity of the paint finish and to prevent infiltration of water and air. See our pamphlet Maintenance Guide for more information.

CLEANING

A quarterly cleaning with a mild soap and sweet water (clean water) solution is recommended for the panels and frames, (all extrusions on Ultra and VistaLuxe Series products); then rinse. Note: Cleaning on units in high salt spray areas requires a monthly cleaning and rinse. Clean glass with any standard glass cleaner, keeping it from running down the panel onto the frame and weatherstrip. DO NOT pressure wash!

HARDWARE

- Install the single point lock, optional foot bolt/secondary security lock and screen according to their directions.
- Check all fasteners, making sure all hardware is properly secured.
- Clear any debris from strike openings, grooves, rails, moving parts or other areas where hardware is engaged, particularly any applicable areas on the sill.
- Clean water should be used to flush the hardware clean. A mild (hand wash) dish soap and clean water mixture can be used to loosen stubborn dirt. Always rinse the hardware with clean water. Allow the hardware to dry completely before lubricating.
 - **DO NOT USE THE FOLLOWING:** Vinegar based cleaners. Citrus based cleaners (lemon, etc). Industrial Strength cleaners. Abrasive cleaners. These types of cleaners will not only remove the lubricants from the hardware, they can also remove the corrosion resistant coatings.

Lubrication:

- Avoid over-spraying or applying lubricant on wood, painted, or vinyl components.
- Recommended Lubricants:
- WD-40: Suitable for sliding or rotating mechanical joints such as rollers, pivots, brackets, hinges, and chains. Avoid contact with wood, finishes, or plastics.
 - Light oil (e.g., 3-in-1 oil): Can be used on sliding and rotating joints. Avoid contact with wood, finishes, or plastics.
 - Graphite: Ideal for sliding and rotating joints as well as locks and hinges.
 - Silicone sprays: Use a straw applicator for precise application. Be cautious as silicone can make some plastic parts brittle and negatively affect wood, painted areas, or vinyl components.

Please refer to the "CARE AND MAINTENANCE OF WINDOW AND DOOR HARDWARE" manual for comprehensive instructions on maintaining your door hardware. Manual can be found on the Kolbe website.

INSULATING GLASS

Broken or fogged IG units, requiring re-glazing or replacement, refer to your Kolbe window & door supplier.

NOTE

Kolbe's standard insulating glass has a LoE coating on surface two (2). It does not match clear glass or other LoE products. Do-it-yourself re-glazing/replacing without Kolbe & Kolbe's permission, will void the product's warranty.

RECYCLING

- Care must be taken to properly recycle or dispose of old materials.
- Separate recyclable materials from non-recyclable materials.
- Please consult with local or state authorities regarding proper disposal of non-recyclable materials.

Contact your Kolbe window and door supplier or visit us
at www.kolbewindows.com for further information.

THANK YOU
FOR PURCHASING KOLBE PRODUCTS

*Kolbe & Kolbe Millwork Co., Inc. reserves the right to
change specifications without notice.*

2025 Kolbe & Kolbe Millwork Co., Inc.