

KOLBE®

WINDOWS & DOORS

FORGENT® SERIES

All Glastra® & Wood Glastra®
V707 Standard & Impact Mulling of
Double Hung, Sliding & Studio Windows
INSTALLATION INSTRUCTIONS

**READ AND COMPLETELY UNDERSTAND
THESE INSTRUCTIONS
BEFORE STARTING ANY INSTALLATION**

⚠ CAUTION

Lead-based paint may be present in older homes, and the removal of windows & doors may cause this paint to be disturbed. In order to minimize exposure to lead-based paint dust, please consult www.epa.gov/lead for more information.

Installer: DO NOT DISCARD Please leave the Installation Guide with the home owner to file for future reference. If you have any questions about this or any of our products, please call your local Kolbe dealer.

NOTICE

Proper installation and periodic home maintenance of Kolbe windows & doors is essential for upholding and sustaining the quality of our products. Failure to install and maintain our product according to these instructions will void any warranty, written or implied. The installer is responsible for consulting the contractor, structural engineer, architect, or consumer, for proper installation according to local codes and/or ordinances.

NOTICE

Some codes require the use of pressure-treated lumber to line the rough openings. Corrosion resistant materials, such as stainless steel or hot-dip galvanized steel, must be used for fasteners and anchors having direct contact with pressure-treated lumber.

NOTICE

Before applying sealant or adhesive pads, ensure the area to be sealed is clean, dry, and frost-free. Use color-matching or transparent sealant. Photos show contrasting sealant for clarity and demonstration only.

⚠ WARNING

Improper use of hand/power tools could result in personal injury and/or product damage. Follow manufacturer's instructions for safe operation of equipment.

⚠ WARNING

Proper Eye and Hearing Protection must always be worn when installing, removing or performing adjustments to Kolbe window and door products.

INTRODUCTION

Proper installation and maintenance of this product is essential to its performance. The following instructions are to be used as guidelines only. Kolbe recommends consulting a local Kolbe supplier or an experienced contractor, architect, or structural engineer since every installation is different. Installation of this product is the sole responsibility of the architect, contractor, building owner, or consumer and Kolbe has no responsibility in this regard.

- **CAUTION:** Lead-based paint may be present in older homes, and the removal of windows may cause this paint to be disturbed. In order to minimize exposure to lead-based paint dust, please consult www.epa.gov/lead for more information.
- In light of the exterior film's low surface tension and dirt repellent characteristics, it is important that proper sealants are chosen and used for sealing the perimeter of the window and door frames to the surrounding building structures. Sealants that have been approved are Dow Corning 758 silicone sealant and Dow Corning 795 silicone sealant.

RECYCLING

- Care must be taken to properly recycle or dispose of old materials.
- Separate recyclable materials from non-recyclable materials.
- Please consult with local or state authorities regarding proper disposal of non-recyclable materials.

ITEMS REQUIRED BY INSTALLER

- Steel Toe Footwear
- Hard Hat
- Sealant
- Harness and Tie offs (per site regulations)
- Safety Glasses
- Cordless or Pneumatic Reversible Driver
- P2 Phillips Head Bits (6 inches long)
- Cordless or Pneumatic Caulk Gun
- Level
- Tape Measure
- Construction Pencils
- Rubber Mallet
- 11/64" and 3/8" Drill Bits
- Impact Drill

PRELIMINARY PREPARATION

1. **Unpacking:** Remove and properly dispose of all shipping and packaging materials. These materials may include the protective shipping film and covers on the exterior of the frame, cardboard wrapping, skid plates, factory bracing, or factory applied ridged or strap handles attached to the frame.
2. **Positioning:** Place the window(s) on a clean, flat work surface with the exterior side facing up.
3. **Assessment:** Ensure the unit is undamaged. Take note of its size dimensions for reference.
4. **Hardware Check:** Verify that all necessary hardware, including screws, brackets, and handles, is present.

Installer: DO NOT DISCARD Please leave the Installation Guide with the home owner to file for future reference. If you have any questions about this or any of our products, please call your local Kolbe dealer.

PREPARE ROUGH OPENING

Before installation, inspect window rough openings to ensure they meet proper size requirements per window. Ensure it is plumb, square, and level for a precise fit.

- IMPORTANT** The material/lumber quality and fasteners must be structurally adequate for design load requirements.
- Typically, the rough opening is to be sized 1/2" (13mm) wider and 1/2" (13mm) higher than the outside measurement of the window frame.
- The rough opening must be plumb, square, level, and in plane. Remedy any discrepancies.
- Ensure individual construction members are not twisted.
- The sill plate beneath the unit must be perfectly level for proper unit operation.

⚠ CAUTION

When installing into a wall with exterior rigid foam insulation panels, place solid blocking material behind the brickmould to provide proper support when fastening the unit.

⚠ CAUTION

Before applying sealant, make sure the area to be sealed is clean, dry, and frost-free. Use color-matching or transparent sealant.

SELECT INSTALLATION TECHNIQUE

These techniques are general guidelines only, and may not be appropriate for all performance requirements. Kolbe recommends three installation types. Choose the best installation method for your situation. 2.0 Double Hung Direct Sets are shown throughout the instructions for simplification. To see the differences between a double hung and casement direct set frame, (Fig. 9 on page 4).

Technique #1: Nail Through the Nail Fin Method:

During nail through the nail fin installation, you will fasten the window by driving 1-1/2" galvanized roofing nails into every pre-punched hole in the nailing fin. Make sure nail fins lie flat as possible.

Technique #2: Installation Clip Method:

(Fig. 1) When using the installation clip method the installation clips are not factory applied and are installed in the field. Attach the installation clips to the frame now. The installation clips are installed by turning the clip catches into the frame. Use one #8 x 3/4" self-drilling screw per clip. On impact rated units the clips are placed 6" in from each corner and 12" on center.

Technique #3: Screw Through Frame Method:

If chosen during ordering, the frame will come pre-drilled from the factory at the head and sides. The sill will need to be pre-drilled during installation. Shims are required to be placed at the same locations as the fasteners to prevent bowing of the frame. Use #8 x 2-1/2" screws spaced 6" from each corner and 12" on center to attach the unit to the opening.

Mullions:

(Fig. 2) On mullied assemblies, nail fin, installation clips or screw through the frame installation may be used. However, screw through the frame installation is required along the mull side at 6" from the corners and 12" on center thereafter.

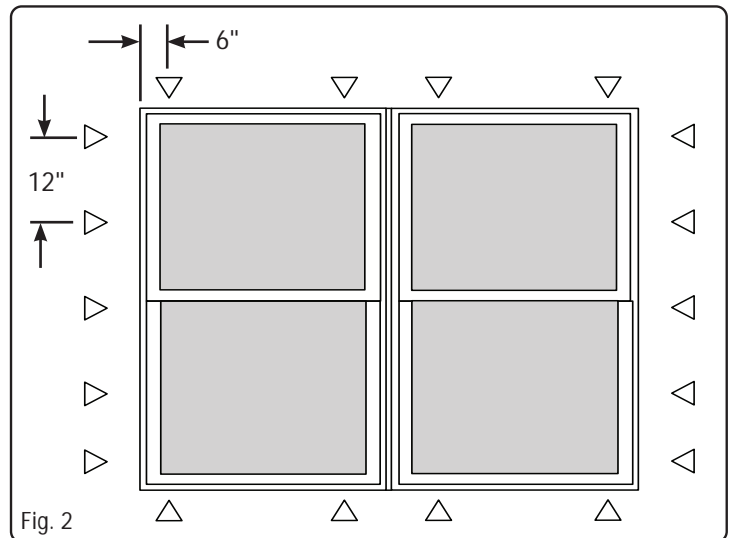
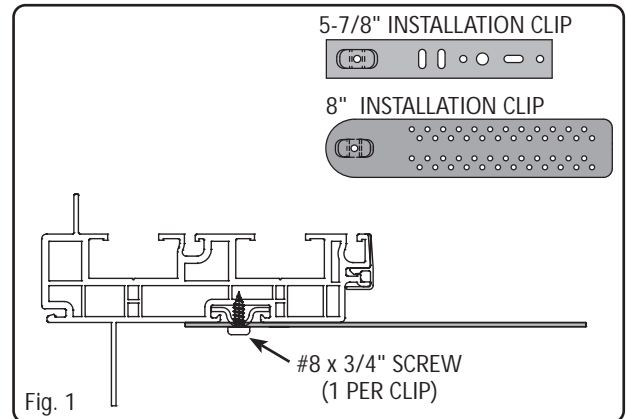

Shimming is required around each installation clip and shims are also required at each screw location. This ensures that the frame does not bow at the sealed mull joints.

SEALANT AND FLASHING

- Kolbe recommends following ASTM E 2112 guidelines for sealing and flashing exterior windows.
- Maintain a gap of at least 1/4" (6mm) on each side, head, and sill between the window frame and the rough opening structure. Creating an overall 1/2" (12mm) taller and 1/2" (12mm) wider than the window frame.
- Create a proper seal between the window and the building framing and exterior.
- For additional details not shown in the following instructions, (our pamphlets *Sealant Information* and *Flashing Information*. These publications are available from your Kolbe window and door supplier or visit www.kolbewindows.com to download a copy.
- The guidelines in this instruction are intended for utilizing a surface barrier system. If employing a membrane drainage system, please refer to our *Sealant and Flashing Instructions* for appropriate sealing methods.

⚠ CAUTION

Before applying sealant, make sure the area to be sealed is clean, dry, and frost-free. Use color-matching or transparent sealant.

MULLION ASSEMBLY

- Remove nail fin from sides to be mullied if not already done.
- There are two options for field mulling your units. *Mull Option 1:* Mull the units and then install in the opening or *Mull Option 2:* install the impact mull reinforcement into the opening in the proper location and then install and attach the units to the opening and mull at the same time. Choose a method before proceeding with installation.

Mull Option 1:

- Lay the units to be mullied down on a clean, dry & flat surface.
- Remove sash stops for jambliner access (Fig. 15 on page 6).
- (Fig. 3) Align the frames with the impact reinforcement mull between them, positioned as shown in (Fig. 3). Clamp the units and mull together to hold the impact reinforcement mull in place.
- (Fig. 4) Secure together with screws, spaced 6" from each corner and 12" on center through the frame and into the reinforcement mull at each hole location on both sides of the mullied jambs. Screw size is determined by unit type, (Fig. 4) for correct screw size. Remove the clamp once all screws have been installed.

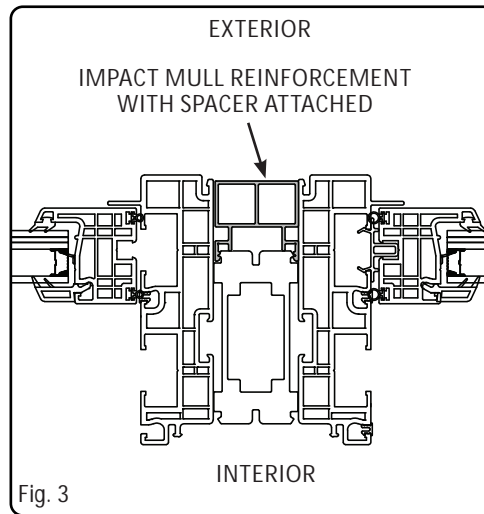

Fig. 3

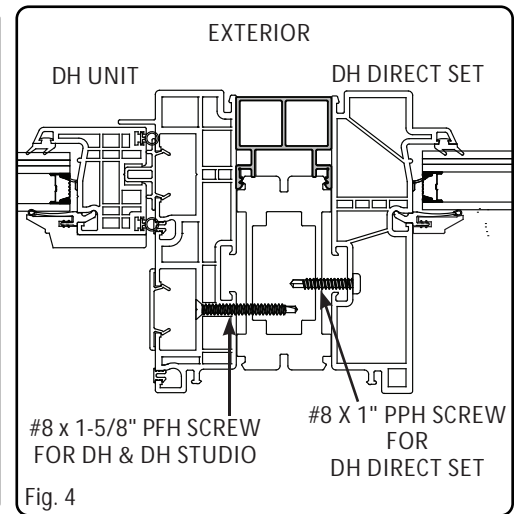

Fig. 4

- Place the offset impact brackets into the end of the impact mull reinforcement as shown in (Fig. 5). The offset part of the bracket faces the exterior.
- Move to **GENERAL INSTRUCTION FOR ALL INSTALLATION TECHNIQUES PAGE 4** now.

Mull Option 2:

- (Fig. 5) Insert one offset impact bracket into each end of the impact mull reinforcement.
- Determine proper placement of brackets in the rough opening and mark location. (Unit configuration and size will determine side to side placement in rough opening.)
- (Fig. 6) Place the brackets and mull reinforcement in the correct location in the rough opening and fasten in place. The impact mull reinforcement exterior face should sit 1" past the exterior wall or the offset impact bracket fastener holes will be 4-7/16" & 4-15/16" behind the nailing fin, (reference the anchor requirements on the next page for securing the impact brackets to the rough opening).
- Now that the impact mull reinforcement is in place, the units are ready to be installed into the rough opening and secured.

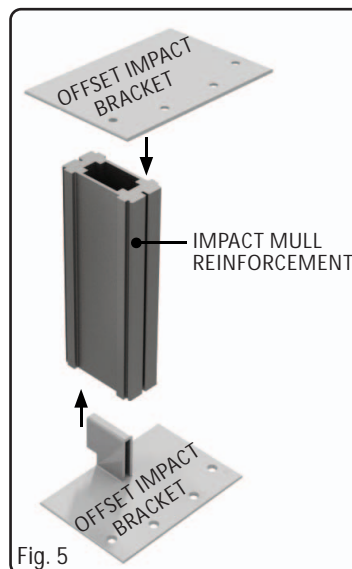

Fig. 5

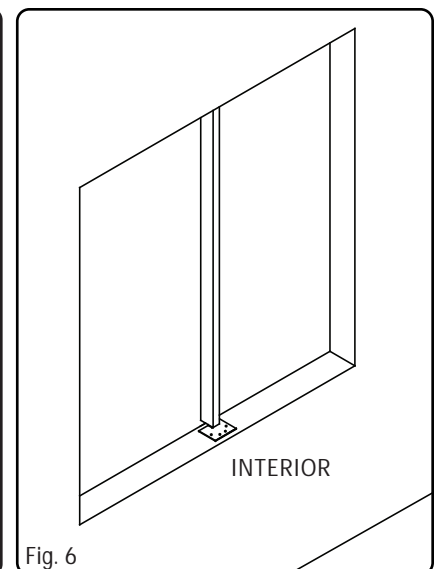

Fig. 6

ANCHOR REQUIREMENTS TABLE			
OPENING TYPE (SUBSTRATE)	FASTENER TYPE	MINIMUM EMBED	MINIMUM EDGE DIST.
CLIP SCREWS			
MIN. 2X4 WOOD FRAME OR BUCK (MIN. GR. 3 & G=0.55)	NO. 10 SMS OR WOOD SCREW	1 1/4"	1"
MIN. 18 GA. 33 KSI METAL STUD	NO. 10 SELF TAP/DRILL SCREW	FULL	1/2"
MIN. 1/8" THK A36 STEEL	NO. 10 SELF TAP/DRILL SCREW	FULL	1/2"
MIN. 0.100" THK 6063-T5 ALUM.	NO. 10 SELF TAP/DRILL SCREW	FULL	1/2"
MIN. C-90 CMU	(1) 3/16" CONCRETE SCREW	1 1/4"	2"
MIN. 2500 PSI CONCRETE	(1) 3/16" CONCRETE SCREW	1 1/2"	2"

(1) CONCRETE SCREWS SHALL BE ELCO ULTRACONS, ELCO CRETE-FLEX, ITW RAMSET/RED HEAD TAPCONS OR HILTI KWIK-CON II (C.S. OR S.S.).

GENERAL INSTRUCTIONS FOR ALL INSTALLATION TECHNIQUES

- Check opening size to ensure the unit assembly will fit.
- If using installation clips, ensure they are attached to the unit prior to starting installation (Fig. 1 on page 2). Installation clips should be spaced 6" from each corner and 12" on center thereafter, (Fig. 7).
- Slide the offset impact bracket into the impact mull reinforcement (if using *Mull Option 1*) (Fig. 5) on the previous page.
- Remove nail fin from sides to be mullled if not already done.
- Apply a 3/16" (5mm) bead of sealant to the nail fin as shown in (Fig. 8). Sealant is required at the head and jambs. No sealant required at the sill.
- From the exterior, carefully tilt unit, sill first, into the rough opening. Press the nailing fin evenly against the exterior sheathing.
- *Mull Option 2 Only:* Place the unit(s) tight up against the impact mull reinforcement in the rough opening. If the unit is not tight to the mull reinforcement the exterior and interior mull covers will not fit. Secure the unit(s) to the impact mull reinforcement as shown in (Fig. 9). Place screws 6" from each corner and 12" on center thereafter through the frame and into the aluminum reinforcement mull. Screw size is determined by unit type, (Fig. 9) for correct screw size.

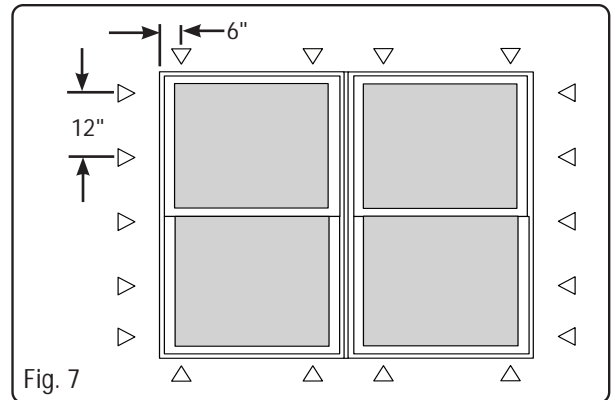

Fig. 7

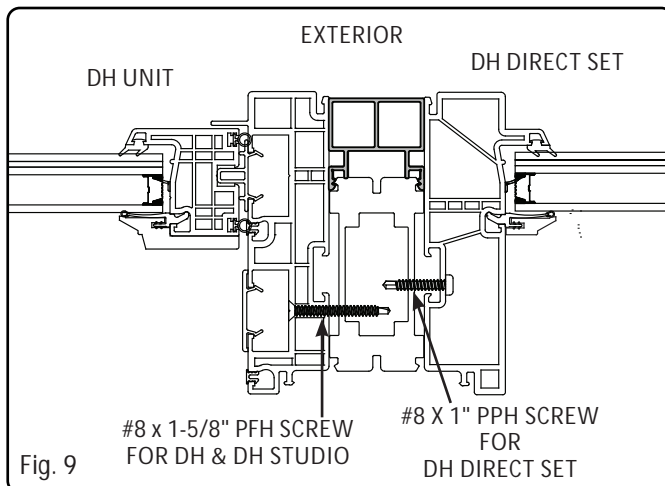

Fig. 9

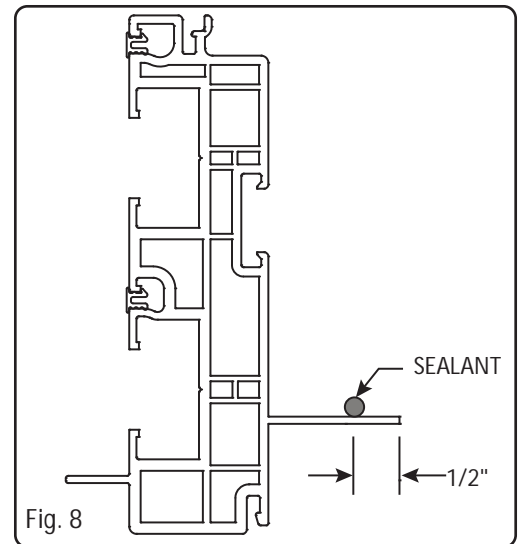
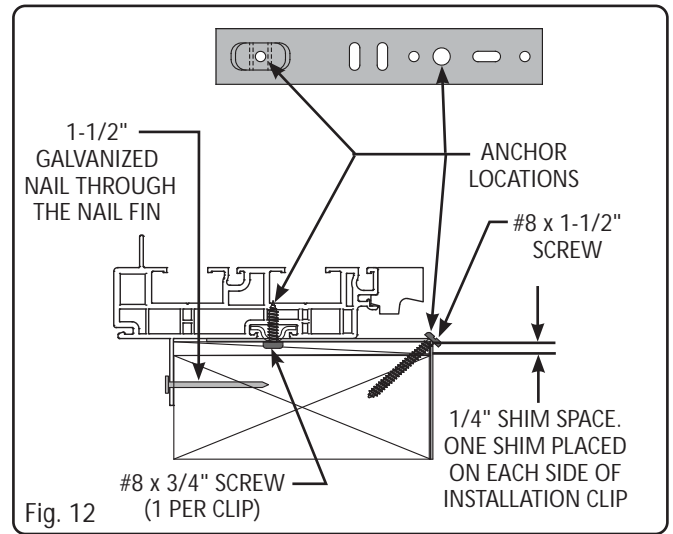
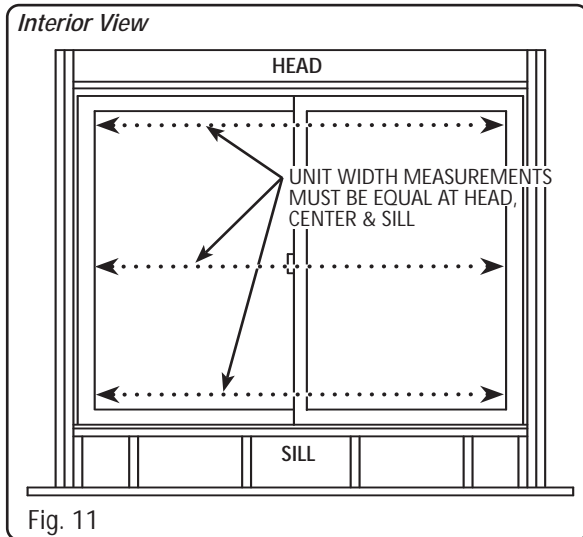
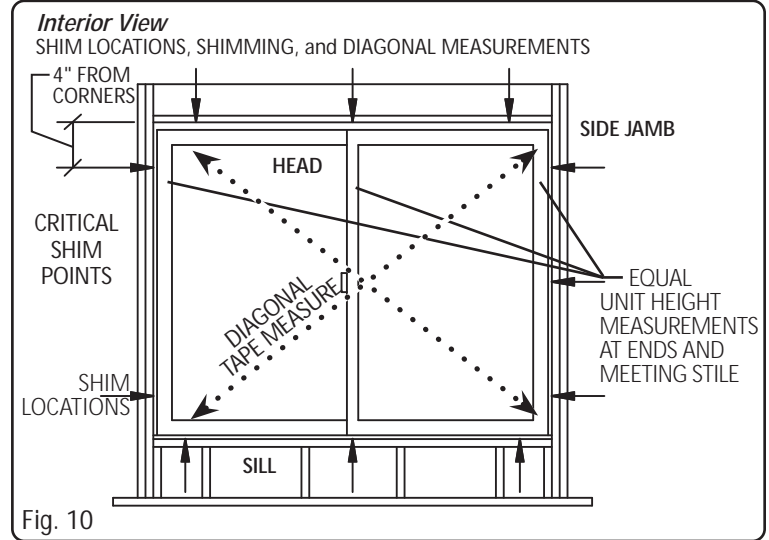

Fig. 8

- (Fig. 10) Shim along the head, sill, and side. Shimming will ensure correct margins, parallel jambs, a level unit, and proper operation. Do not bow the side jambs. Do not over shim.
- (Fig's 10 & 11) Measure the distance from the interior upper left frame corner diagonally down to the lower right frame corner, and then measure the other two corners. These measurements must be within 1/16" (2mm) of each other. In addition, the height of the frame at the center must be the same as the height at each end. The margins around the window should be even on all sides.
- *Mull Option 1 Only*: Referecne the anchor requirements on Page 4 for securing the impact brackets to the rough opening.
- Secure unit in place using chosen installation method below.



Technique #1: Through the Nail Fin:

(Fig. 12) Fasten the window in place by driving 1-1/2" galvanized roofing nails into every pre-punched hole (approximately every 4") in the nailing fin. Make sure nail fins lie as flat as possible.

Technique #2: Kolbe Installation Clips:

(Fig. 12) Double-check to ensure the sill is straight and level. Plumb the side jambs and level the head jamb. Shim on both sides of every installation clip to prevent the frame from bowing. Starting with an interior upper corner, bend clips to the rough opening frame and fasten using #8 x 1-1/2" (38mm) Phillips pan head screws. Continue around the perimeter, making sure the jambs are straight and the unit is square.

Technique #3: Screw Through the Frame:

Double check to ensure the sill is straight and level. Plumb side jambs and level the head jamb. Remove the head insert (Fig. 13), then the sill riser (Fig. 14 next page) and finally the sash stops on the side jambs (Fig. 15 next page) from the frame prior to starting screw through the frame installation.

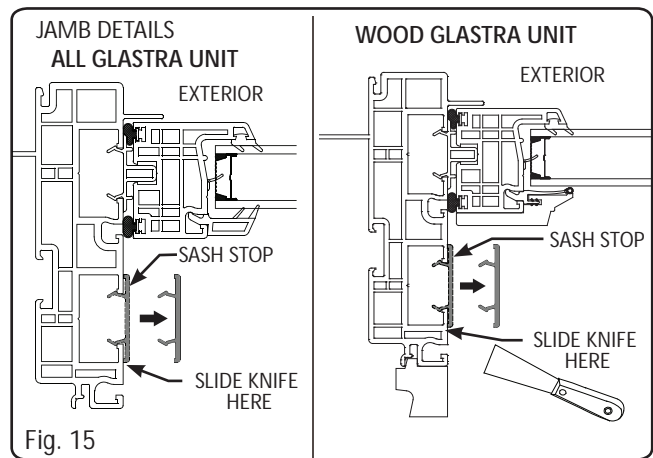
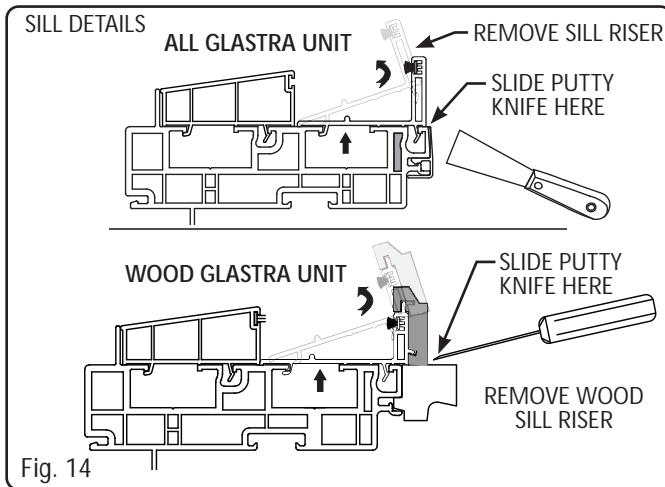
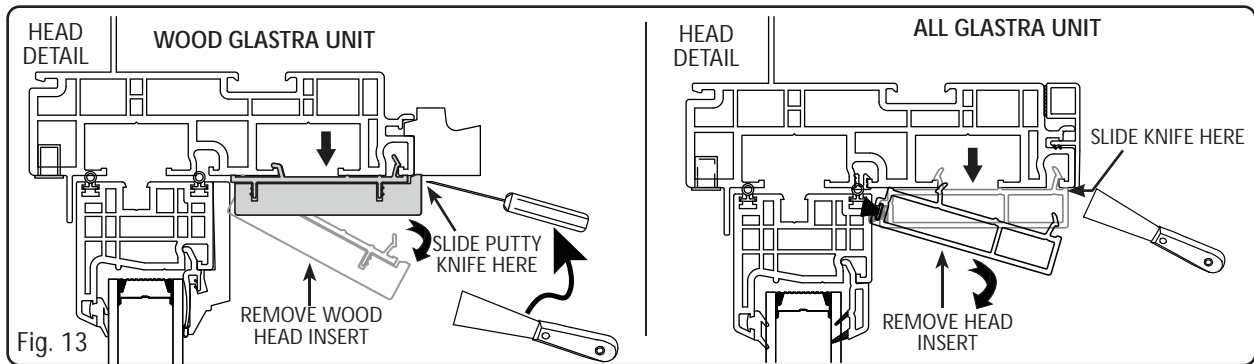

(Fig. 16) **Sill:** Mark screw locations 6" in from corners and 16" on center thereafter on the sill.

Insert a shim at each marked screw location to support the frame and maintain alignment. Confirm that the window unit remains level before drilling. Using a 9/64" (4mm) drill bit, create pilot holes through the sill, shim, and into the rough opening at each marked location. Secure the frame using #8 x 2-1/2" (64mm) Phillips flat head screws through the pilot holes. Apply sealant to the heads of the screws installed in the sill to prevent water infiltration.

Head and Jamb: Pre-drilled holes are located at the head and jambs.

Secure the head and jambs with #8 x 2-1/2" (64mm) PH screws.

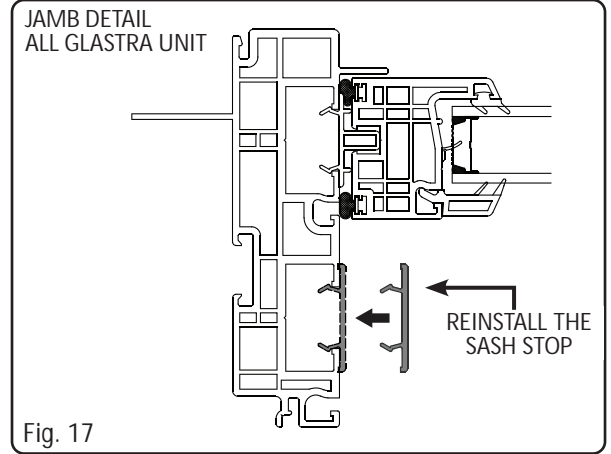
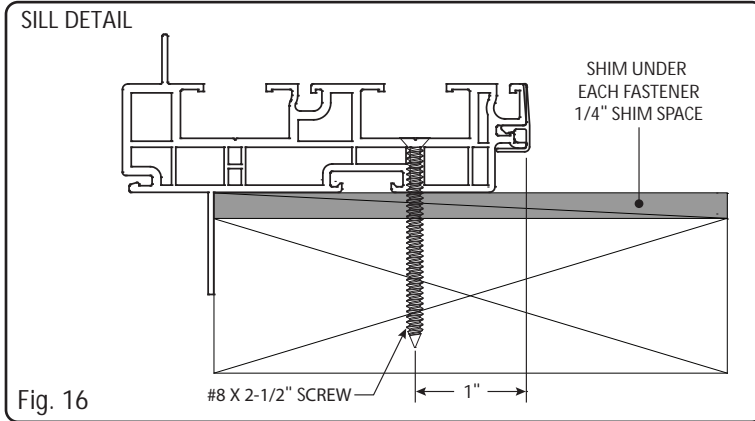

Re-install the sash stops (Fig. 17) on the side jambs, and then re-install the head insert (Fig. 18) at the head.

Next, run a bead of sealant along the entire length of the sill (Fig. 19) and replace the sill riser (Fig. 20) at the sill.

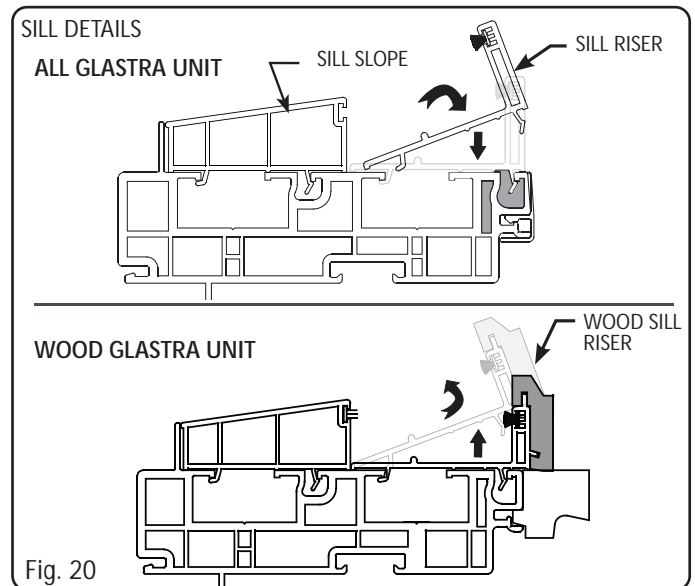
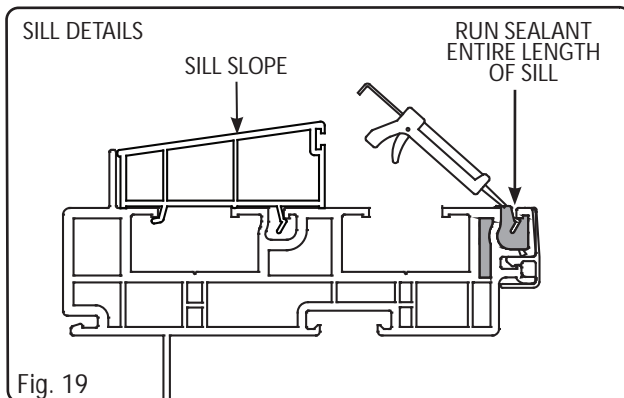
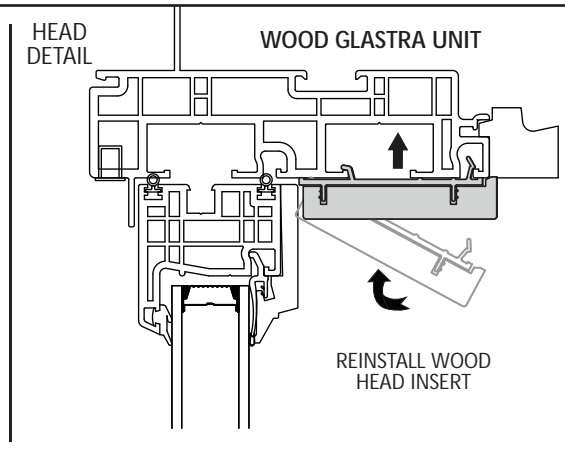
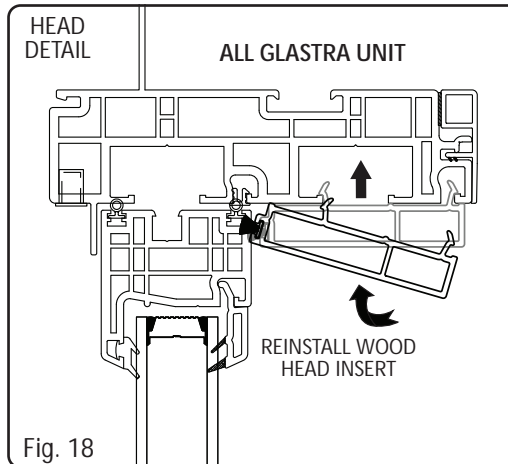

PREPARE FRAME ACCESSORY GROOVE - Mulling or Applying Accessories to Units with Exterior Foil

(Fig. 21) For units with exterior foil, ensure the foil is trimmed out of the exterior accessory groove where mull covers will be installed. Failure to do so may result in the frame leg breaking due to laminate buildup in the groove.

(Fig. 22) Use a utility knife and score the laminate along the one side of the accessory groove as shown.

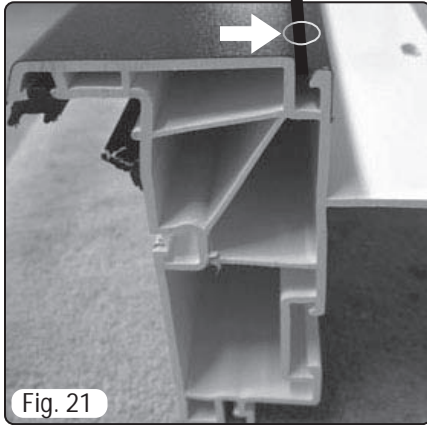

Fig. 21



Fig. 23

CUT ACCESSORY
GROOVE OPEN

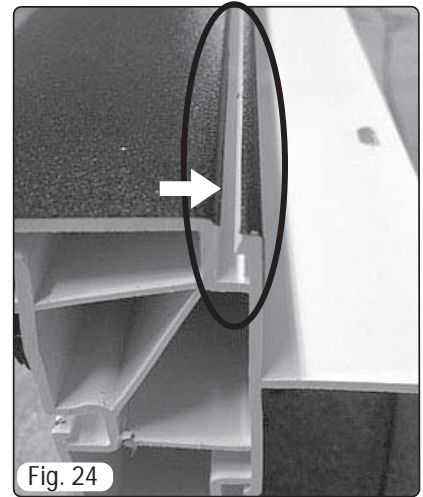

Fig. 24

ACCESSORY GROOVE IS
SHOWN CUT OPEN

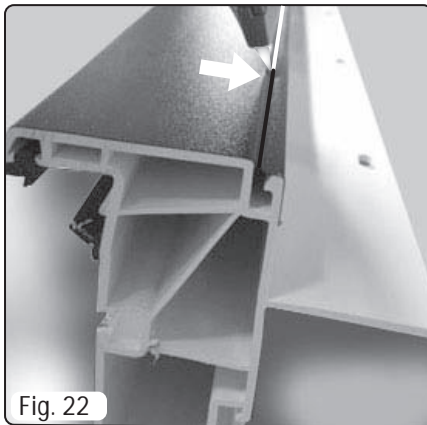

Fig. 22

(Fig. 23) Score the other side of the accessory groove with the utility knife. Remove the small strip of foil from the frame.

(Fig. 24) The accessory groove should now be open.

MULL COVER APPLICATION

All Glastra units:

- (Fig's 25 & 26) Run sealant along the entire length of the exterior accessory groove for both frames.
- (Fig's 26 & 27) Attach the exterior mull cover to both frames.

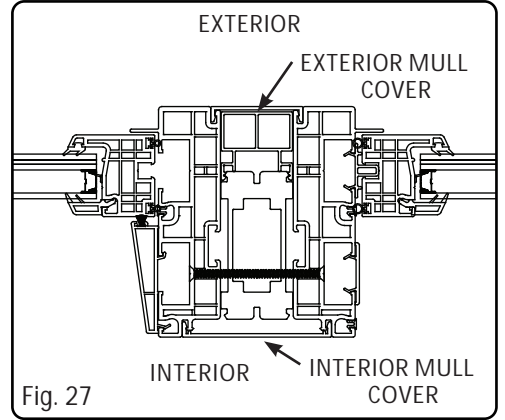
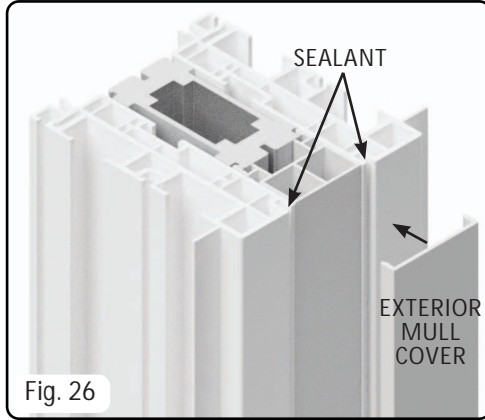
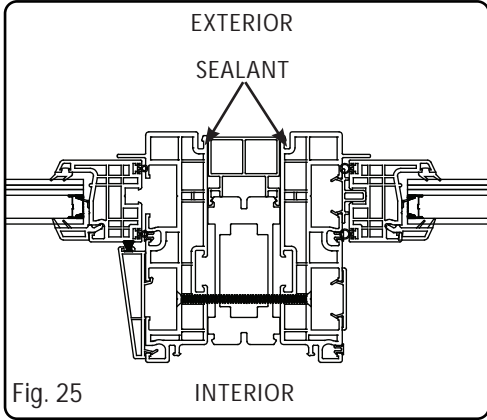

- (Fig. 28 & 29) Drip cap is required at the head. Apply sealant over the mull and to the ends of the drip cap as shown, then apply drip cap at the head.

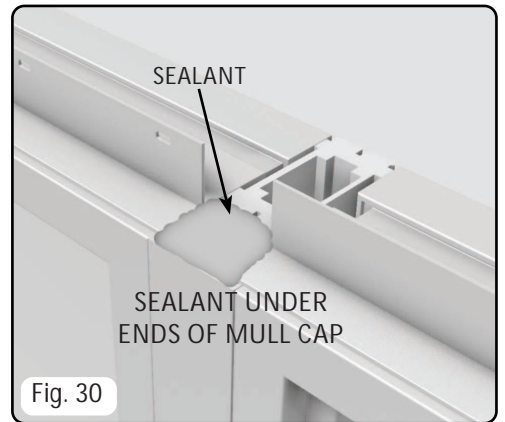
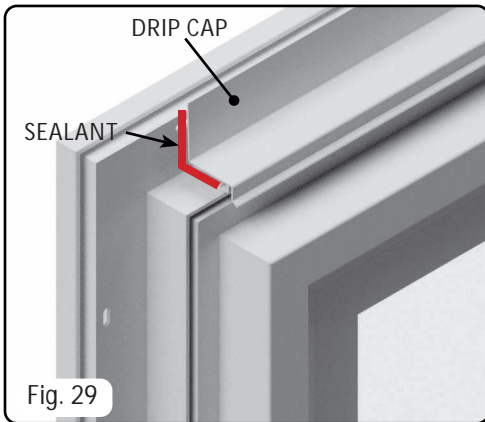
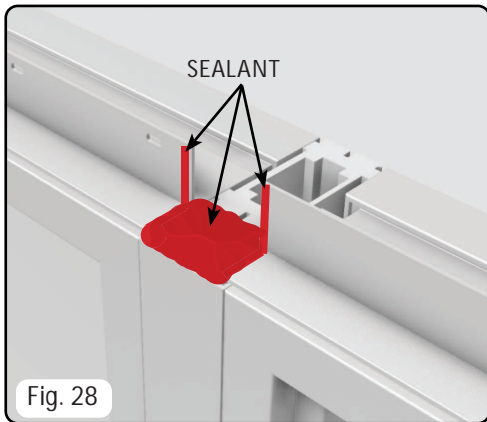

- (Fig. 30 & 31) Fill any remaining open ends of the mull with sealant (Fig. 30). Apply sealant to each end of the mull cap and snap the mull cap onto the frame centered over the mull as shown in (Fig. 31).

- (Fig. 32) Using a pliers or utility knife, remove the interior support legs on the frame, then apply the interior mull cover.

- (Fig's 33 & 34) show an exploded view of the mull assembly and the finished mull assembly, page 9 for part designations.

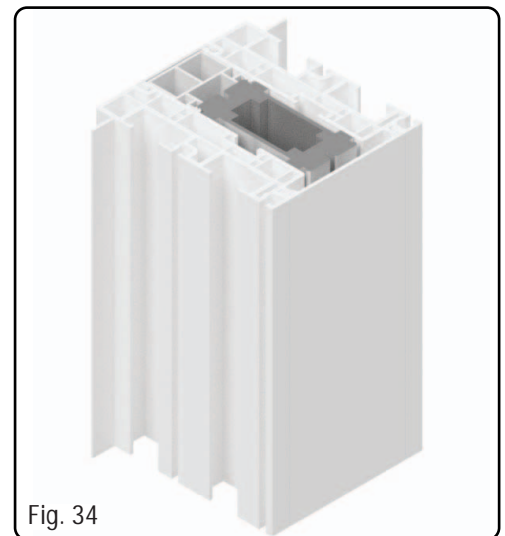
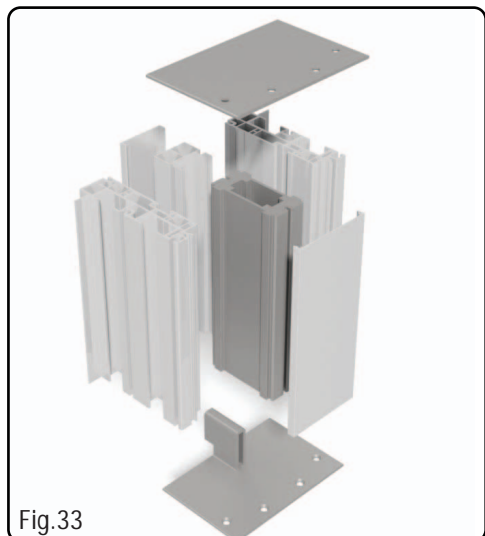
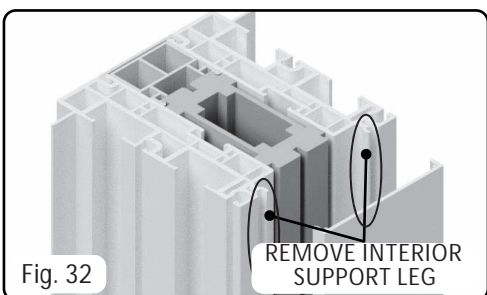
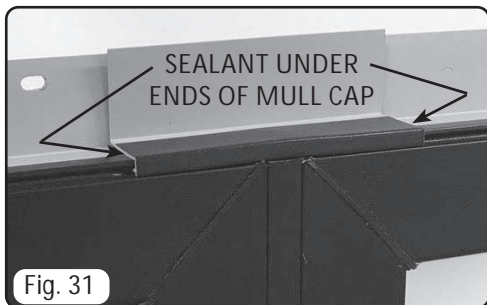

Wood Glastra Units:

- (Fig's 35 & 36) Run bead of silicone sealant along the entire length of the exterior accessory groove for both frames.
- (Fig's 36 & 37) Attach the exterior mull cover to both frames as shown.

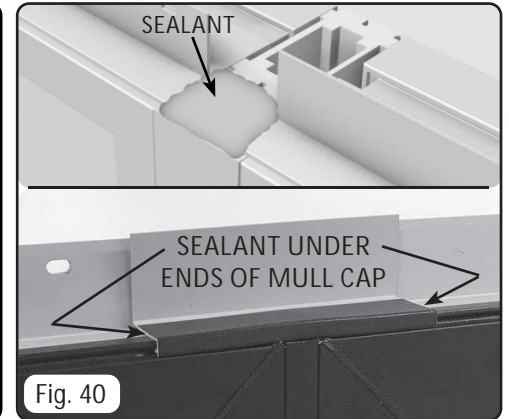
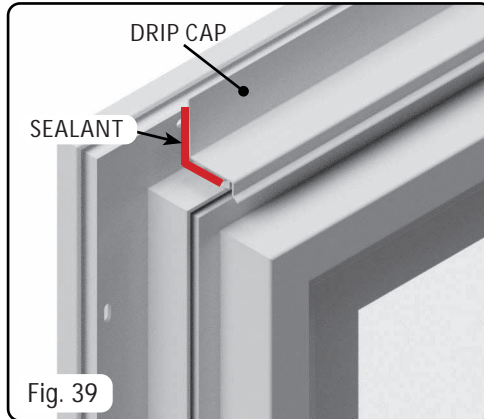
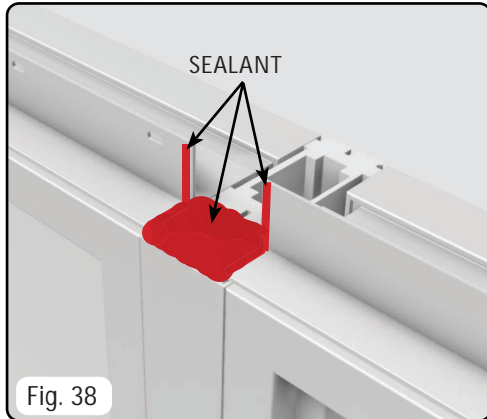
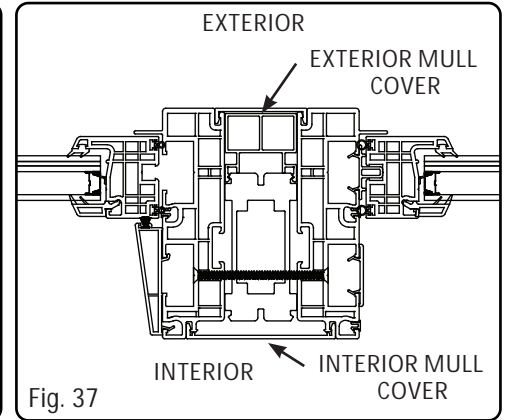
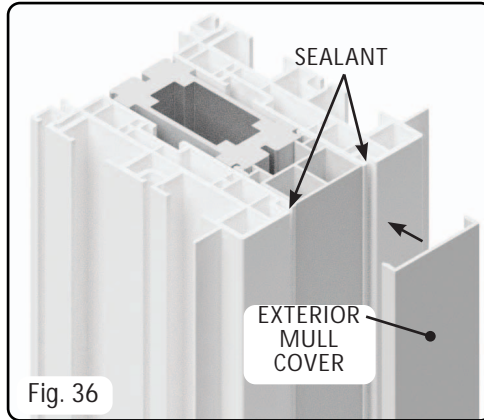
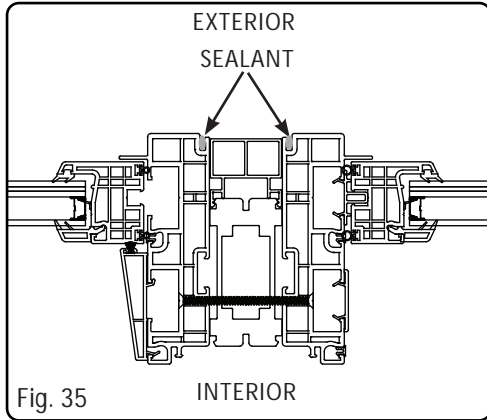

- (Fig's 38 & 39) Drip cap is required at the head. Apply sealant over the mull and to the ends of the drip cap as shown, then apply drip cap at the head.
- (Fig. 40) Fill any remaining open ends of the mull with sealant. Apply sealant to each end of the mull cap and snap the mull cap onto the frame centered over the mull as shown in (Fig. 40).
- (Fig. 41) On the interior apply the impact mull receptor E to the interior accessory grooves. Make sure the catch that snaps into the accessory groove is facing the mull.
- (Fig. 42) Apply your interior wood cladding using a soft hammer.
- (Fig. 42) Brad nail the mull cover cladding by centering the mull cover cladding between the mull cover supports and using a 3/4" brad nail to secure in place.
- (Fig. 43) for parts designation and an exploded view of the mull assembly, reference page 9 for part designations.

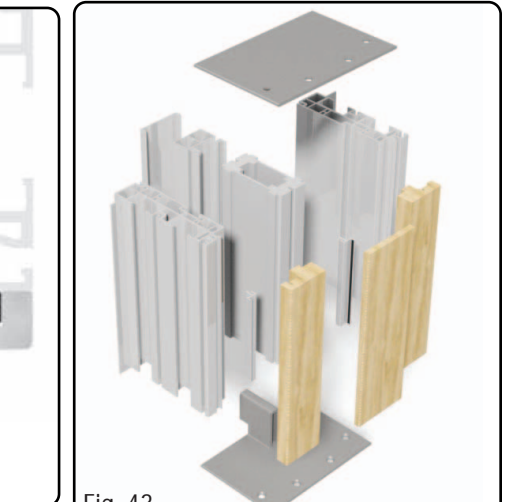
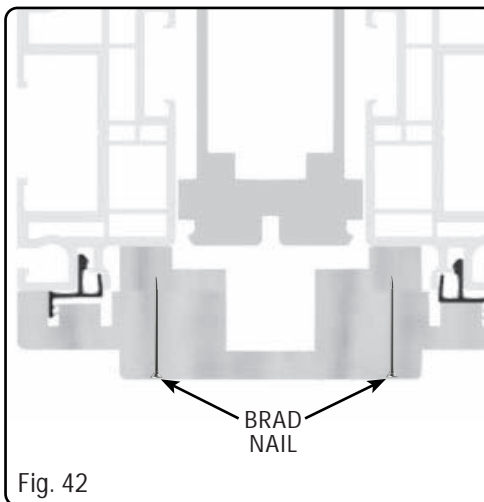
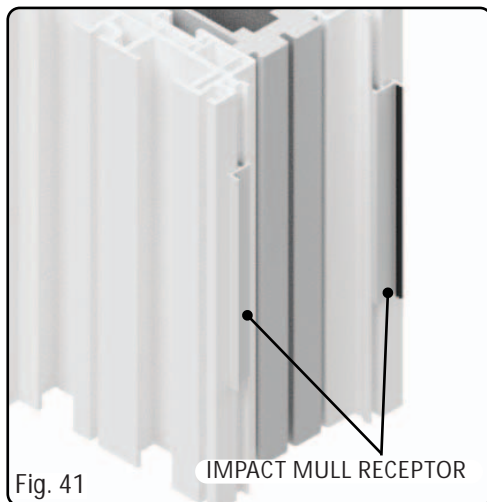

ALL GLASTRA 2.0 DOUBLE HUNG UNIT DETAIL (EXPLODED VIEW)

PARTS DESIGNATIONS

- A - 1-1/2" Impact Reinforcement (MW119)
- B - DH NC Frame (MW061)
- C - 3-1/8" Impact Mull Cover (MW009)
- D - Impact Bracket
- E - 1-1/2" Impact Reinforcement Spacer (MW120)
- F - 2" Exterior Impact Mull Cover (MW025)

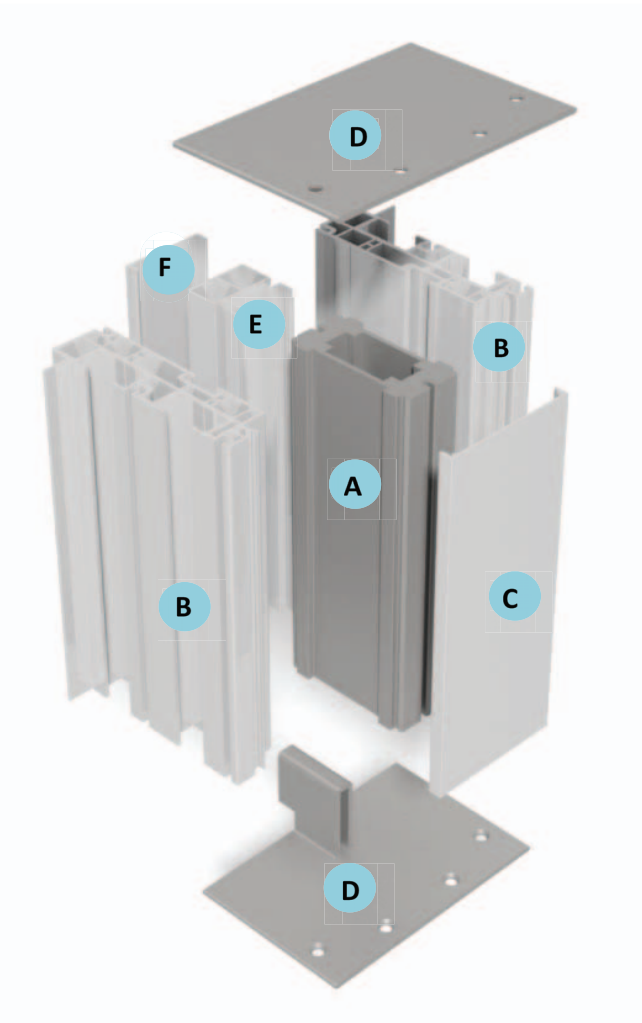

WOOD GLASTRA 2.0 DOUBLE HUNG UNIT DETAIL (EXPLODED VIEW)

PARTS DESIGNATIONS

- A - 1-1/2" Impact Reinforcement (MW119)
- B - DH NC Frame (MW061)
- C - Impact Mull Cover Spacer (4253)
- D - Impact Mull Cover Cladding (4241)
- E - Impact Mull Receptor (MW027)
- F - Impact Bracket
- G - 1-1/2" Impact Reinforcement Spacer (MW120)
- H - 2" Exterior Impact Mull Cover (MW025)

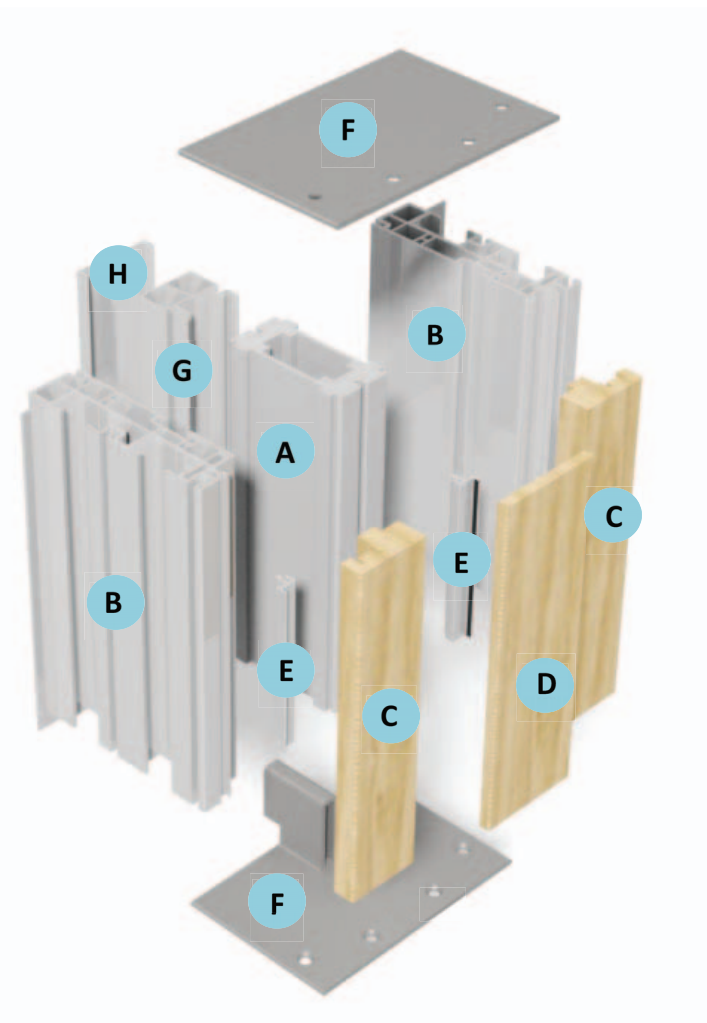

COMPLETING THE EXTERIOR

(Fig's 44 & 45) Install backer rod and sealant around the interior and exterior perimeter of the frame.

Both components are required to seal the window to the self-adhering flashing when no nailing fin is required.

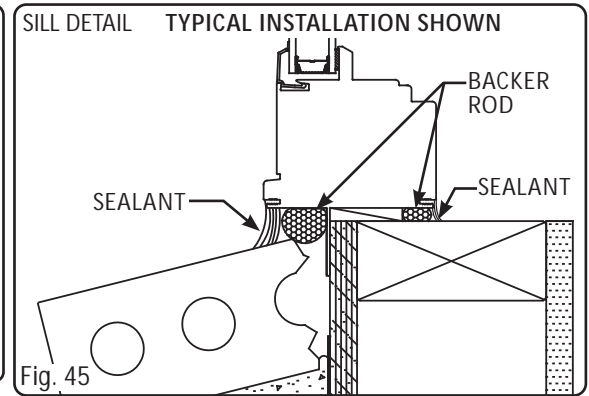
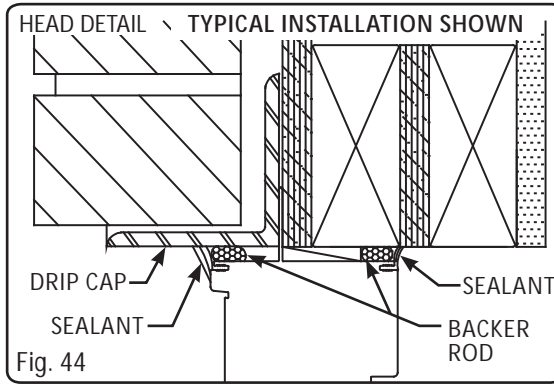

DRIP CAP APPLICATION

A drip cap must be installed to direct water away from the window and lessen the chance of water seepage. The drip cap will be the full length of the width of the unit.

Before applying, follow the next steps:

1. Cut out the exterior film from the exterior accessory groove (Fig's 46 -49).
2. Seal over the mull joint/gap when mulling units (Fig. 48).
3. Seal the side edges of the drip cap to the window (Fig. 48).
4. Run a bead of silicone sealant between the back of the drip cap and the exterior sheathing.

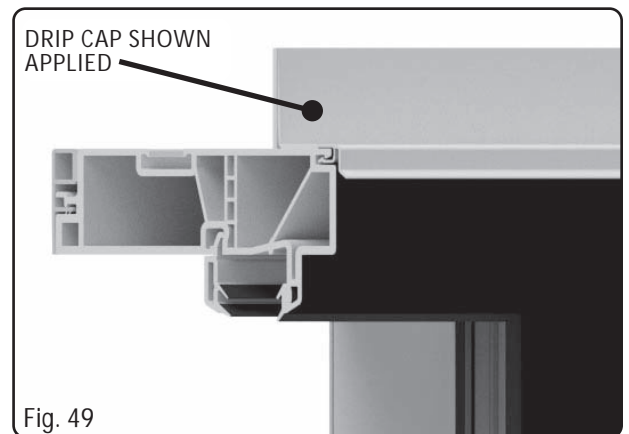
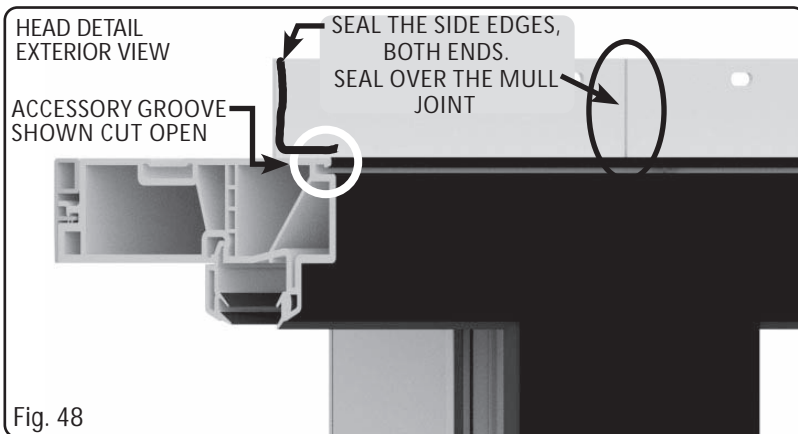
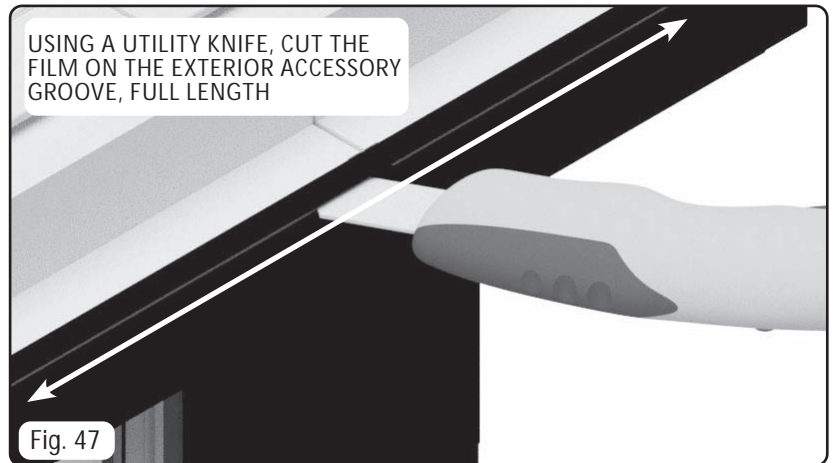
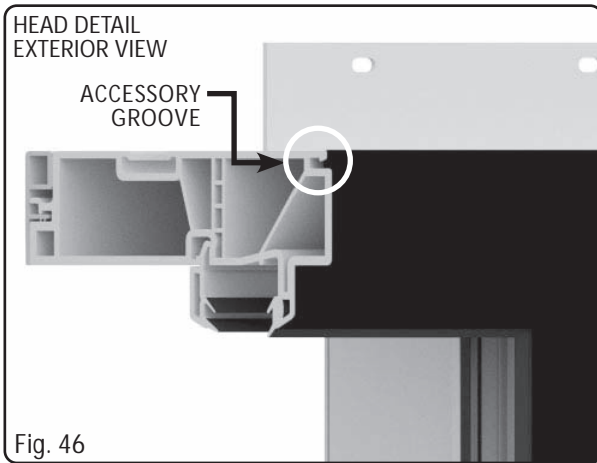

INTERIOR FINISHING

Interior: Finish bare wood interiors immediately using a top quality stain, sealer and/or polyurethane varnish. On factory primed interiors, apply a quality top coat system (reference Kolbe's Pre-finish Recommendations/Instructions for more information). In light of the exterior film's low surface tension and dirt repellent characteristics, it is important that proper sealants are chosen and used for sealing the perimeter of the window and door frames to the surrounding building structures. Sealants that have been approved are Dow Corning 758 silicone sealant and Dow Corning 795 silicone sealant.

⚠ CAUTION

Avoid getting finishing products on any hardware, vinyl components and weatherstripping.

MAINTENANCE TIPS / PROCEDURES

Regularly check your Kolbe products for any gaps, cracks, or damage in the exterior sealants or finishes. Immediately caulk any cracks with a quality sealant to maintain the paint finish and prevent water and air infiltration. Refer to our Forgent Maintenance Guide for more details.

CLEANING

Clean panels and frames quarterly with mild soap and water, then rinse. For high salt spray areas, clean monthly. Use standard glass cleaner for the glass, avoiding drips on the frame and weatherstrip.

⚠ CAUTION

Do not pressure wash!

⚠ CAUTION

Avoid getting finishing products on any hardware, vinyl components and weatherstripping.

HARDWARE

Check all fasteners, making sure all hardware is properly secured. All operating components can be greased or oiled once a year. Security strikers made of steel require continuous greasing in order to avoid unnecessary abrasion.

Contact your Kolbe window and door supplier or visit us at www.kolbewindows.com for further information.

**THANK YOU
FOR PURCHASING KOLBE PRODUCTS.**

Kolbe & Kolbe Millwork Co., Inc. reserves the right to change specifications without notice.

© 2025 Kolbe & Kolbe Millwork Co., Inc.